

Crystal and Space: An application of crystallography in architecture

Enkeleida Beqiraj, Besian Xhagolli

(Assoc. Prof., Geology and Mining Faculty, Rruga Elbasani, ea_beqiraj@yahoo.com)
(Eng., Geology and Mining Faculty)

1 ABSTRACT

This paper tends to reveal the close relations that exist between the crystallography and architecture. The buildings have often forms that are similar or identical with simple or combined crystallographic forms, such as cub, tetragonal pyramid, tetragonal or hexagonal prism, etc. The evidence of this relation between the art and the science is the best communication manner during the education process with students. On the other hand, recognizing the interdisciplinary relations helps them for a better orientation in the framework of job market.

Keywords: crystallography, architecture, form, interdisciplinary, relation.

1. INTRODUCTION

Since the ancient time, a frequently non-apparent relationship between two very different subjects, crystallography and architecture, existed. After a detailed judgement, which considers their respective starts and applications, we understand that the relation between the two above fields is so closely. It is known now the phrase of Da Vinci: “Anknowledge blinds and deceives us\ miserable mortals, open your eyes!” [1].

This paper aims to stress the idea that Crystallography could have been one of the sciences that laied the basis of architecture. During the development of crystallography and architecture in the course of time, they were also influenced by other developments of other branches of science. Anyway, the esence is: the crystal forms were used by people in antiquity as symbols of communication and transmission of ideas, messages and feelings between them. Then, the two sciences followed their respective ways of development, depending on the problems that time has layed for solution and the advance of the new branches of sciences.

French philosopher Michel Foucault (1926-84) was concerned with examining the past as a means of diagnosing the present. For Foucault there was no essential order or meaning behind things, and everything was therefore to be judged according to a framework of knowledge which was forever changing [2].

2. CRYSTAL ARCHITECTURE

Crystallography began as a branch of a natural science in the 17th century and its object of study is crystal and crystal bodies.

The word “crystal” derives from a Greek word for ice and it means “solidified by the cold”. This word was usually applied to rock crystal-quartz. Later on this term was used for all solid minerals with regular shapes.

A crystal form is a set of symmetrically related crystal faces [3].

2.1. Crystalline lattice

Crystal structures are characterized by three-dimensional repetition of unit cells, parallelopipeds with linear dimensions on the order of 50-150pm (5-15 Å); although some are considerably larger than this range. Not only are all proportions of essential chemical elements of a mineral contained in its unit cell, but geometric relationships among chemical constituents are included well.

Unit cell of a crystal structure, is a small volume that contains the simplest asymmetric unit and symmetry elements of the space group that, when repeated infinitely in three dimensions, contains all ions of a structure and all three-dimensional interrelationships among those ions. Thus, a unit cell, while an arbitrary choise, is usually taken as the simplest buiding block of a crystal sructure. Periodicity-patterned repetition in space inherently generates symetry determined by the kind of periodicity.

Motif is the law of atoms array with respect to every point of crystal lattice. It is a static configuration being repeated in the crystal structure by elements of space symmetry [3].

A crystalline lattice is characterized by its unit cell parameters which are lengths of translation vectors and angles between them. The three translation vectors are designated a , b and c . Angles between of translations are α ($b^{\wedge}c$), β ($a^{\wedge}c$) and γ ($a^{\wedge}b$).

Crystal lattice, motif and unit cell are elements for a crystalline structure characterization.

Crystal lattice may be one-dimensional, two-dimensional and three-dimensional (Fig.1a,b,c).

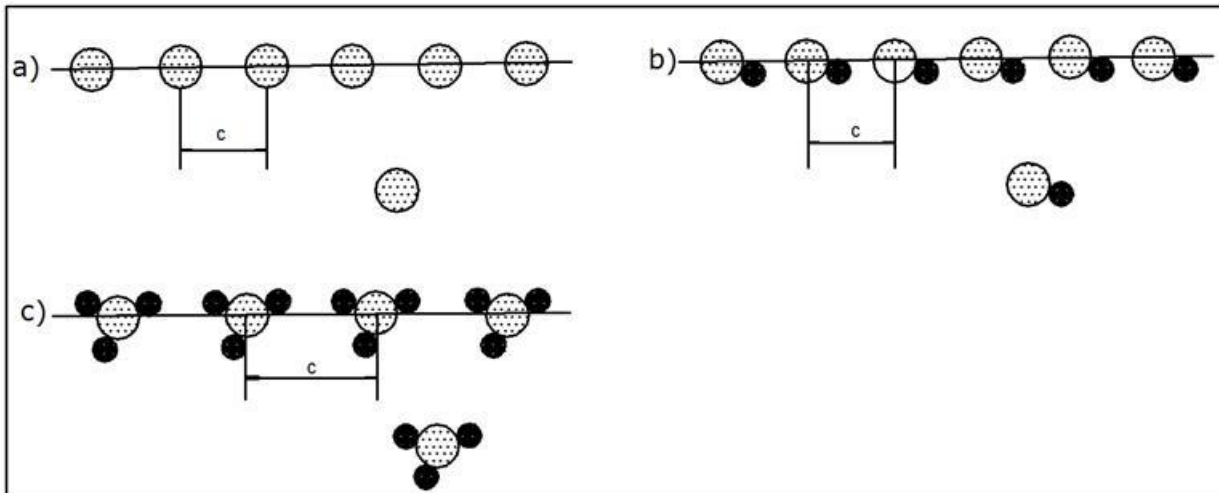

Fig.1-a,b,c. One-dimensional crystal lattice

Plane lattices (two-dimensional) may be oblique, rectangle, rombique, hegzagonal and square forms.

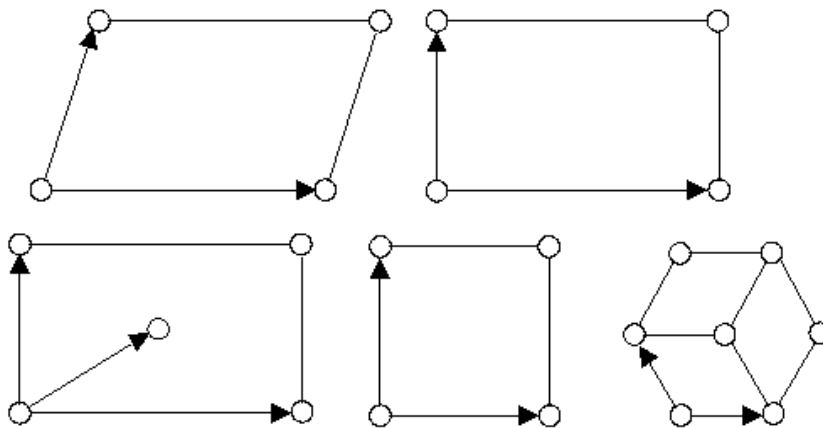

Fig.1-b. Types of two-dimensional crystal lattice

There are 14 types of space lattices called Bravais lattices.

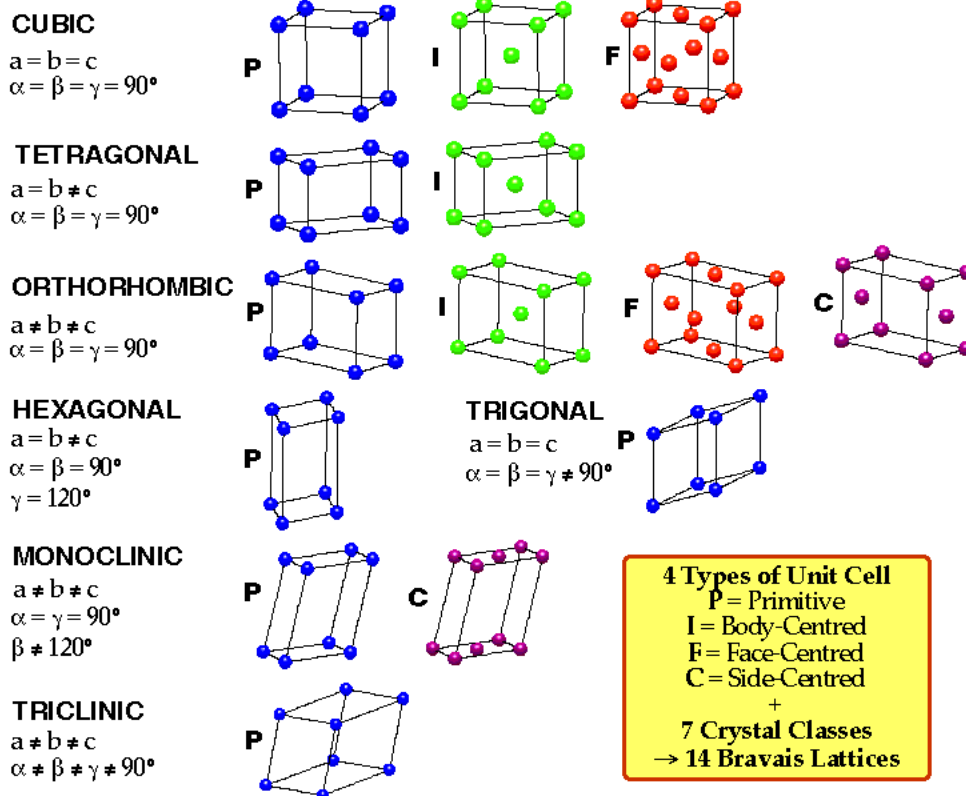

Fig.1-c. 14 types of Bravais crystal lattice

2.2 The symmetry in crystallography

In crystallography, the symmetry expresses the similarity in spatial positioning of the elementary units: sides, faces, edges or other elements of the crystalline structure. The translation is the fundamental operation of symmetry for the crystalline net.

Except symmetry of translation, the crystalline forms may have other kind of symmetry operations like as inversion, rotation, reflection and their combination, but their results must always correspond to those gained by translation [3].

The operations of symmetry are expressed by means of symmetry elements that are: the centre, the axis and the plan of symmetry. These elements are expressed by a defined symbolic consisted of combined letters and numbers, that constitute the crystallographic formulae. These elements may be presented in the crystallographic projections also. The elements of the symmetry are divided in two groups: simple and compound. The compound elements spread their effect by interlacing the simple operations.

2.3. Crystals and macrosymmetry

The crystal represents a regular crystalline solid that is defined by its natural sides. It has its appropriate form that is called morphology of the crystal. The morphology of the crystal is conditioned by the symmetry of the crystalline net. The geometric form of the crystal is characterized by faces, sides and edges.

For every crystal are acceptable these laws:

-The law of constancy of interfacial angles (Fig.2), known as Steno's law. According to this law, the angles between the same two faces of a mineral crystal are identical all its crystals regardless of the size of each crystal or the relative sizes of these two faces.

-The law rational intercepts (Fig.3), which determine that the double proportions of the segments that are divided by two faces of the crystal in its three sides are always equal to the proportions of three whole and small numbers as below:

$$OA_1/OA : OB_1/OB : OC_1/OC = r^*a/u^*a : s^*b/v^*b : t^*c/\ddot{e}^*c = r/u : s/v : t/\ddot{e} = h : k : l$$

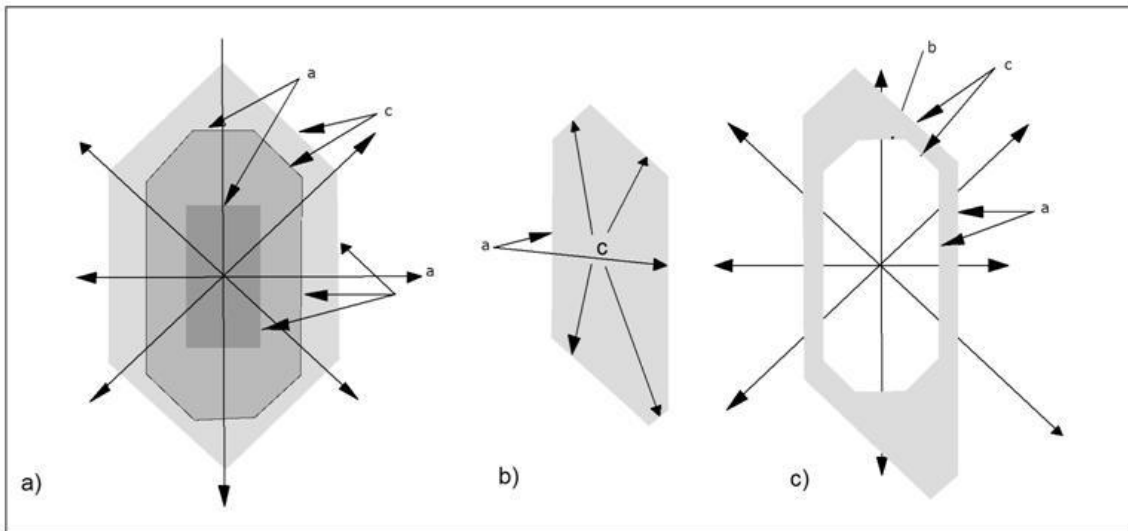

Fig.2. Sketch of the constancy of interfacial angles

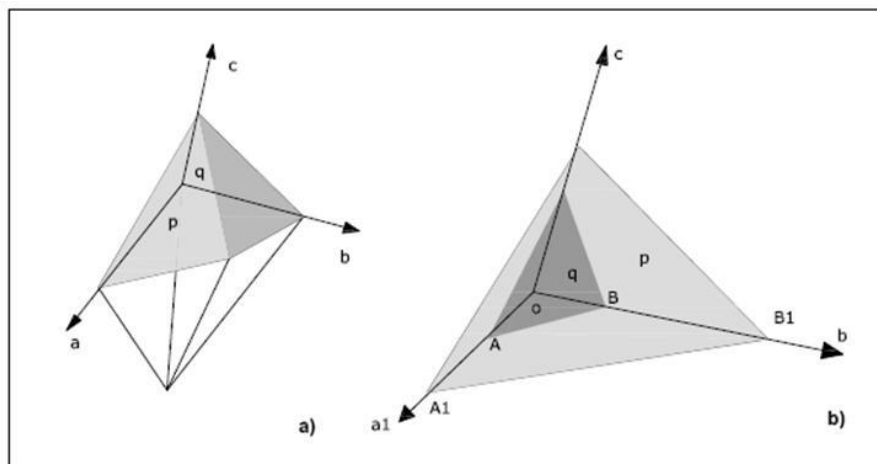

Fig.3. Demonstration sketch of the law rational intercepts

The morphology of the crystal may be defined by a simple or a complex crystalline form. The simple crystal form is a set of symmetrically related crystal faces. In any crystal class one or more crystal faces may be equivalent by symmetry operations that define the point group for that class. The main simple crystal forms are pinacoid, monoeder, prism, bipyramid, etc. (Fig.4a, b, c, d, e).

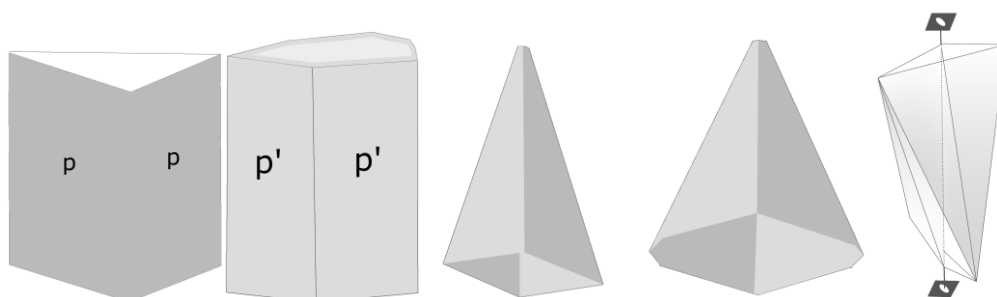

Fig.4a, b, c, d, e. Different simple forms are shown, from the left to the right: trigonal prism; ditrigonal prism; tetragonal pyramid; ditetragonal pyramid; tetragonal scalenoeder.

3. THE BUILDING ARCHITECTURE

Architecture is the object of the theory, and it refers to both process and product. As process, it is art, science, and practice of building designing and construction. As product, it is a vast assemblage of built artifacts and a synonym for the manmade or design environment, which also includes the tamed natural environment that surrounds it. No distinction is made between a certain type of building, sometimes considered as architecture, and another kind of building, sometimes considered as mere construction [4]. By definition, the architectural product has a physical presence. It has to be constructed in order to exist. Before it is built it is not architecture. It is a vision, perhaps a set of drawings or models. If it is demolished, it ceases to be architecture. If ruins remain, it becomes archeology. The architectural product is always in the present, a cultural object as opposed to a natural object, like a pen as opposed to a pebble. The difference is purpose: a cultural object - an architectural product - is always made for a purpose [5].

3.1. Archetype

In architecture, archetype is understood as “first form”; it serves as a model for a design endeavour. An applied archetype is necessarily built, it has a form, and it is referred to as either a type or, merely, a single architectural artifact [4].

4. THE RELATION BETWEEN CRYSTALLOGRAPHY AND ARCHITECTURE

The most essential relation between crystallography and architecture stands in the processes involved in both, up to respective productions. Making crystallography and making architecture means shaping the space. In the first case the space is shaped from the surface of the crystal, while in the second, it is shaped from the surface of a building. A mineral exists due to some determined equilibrium points of power and energy, according to some determined laws, as it is necessary for the building to exist.

For crystallographic form this laws are determined by nature. On the other hand, for the building form, the respective laws are determined by the man (architect). In general, the man has often modeled the nature.

About the birth of art we know no more than about the birth of language. If with art we understand construction processes of temples and houses and creation of the pictures and sculptures, than there is no any people without art. The museums or exhibitions contain a lot of beautiful objects which are art productions that come from recent time, but many of the great builders or sculptors from the antic times, even produced art, they didn't ever think of it. We understand better this distinction between art as production and art as concept when we stop in architecture. It is very difficult to find a building that isn't raised for a certain purpose because the architectural form of the object has always been a function of the purpose to which it would be used [6]. Everybody knows that Egypt is the country of the pyramids that, on one hand, represent a perfect modeling of crystal forms and, on the other, they satisfy the mentality of pharaohs. The architectural form has been the symbol of a certain mentality, in a certain period. Thus the model always was found in the nature. Part of the nature had been the crystals and rocks, also. Nature is fractal and complex, and nature has influenced the architecture in different cultures and in different periods. Complexity is the property of a real-world system [7].

It is not fortuitously, the existence of the same words in terminology of two sciences, such as : “crystallographic form” – “the building form”, “the architecture of the crystal”-“urbanistic architecture”, “crystalline structure”-“architectural structure”, “habitus” (crystallography)-“habitat” (architecture) “crystallographic projection”-“architectural projection”.

In particular, according to the crystallographic definition, “habitus” is to cover the varying development of the crystal forms possessed by any one mineral. According to the relative development or dominance of one or other simple forms, the habit may be for example prismatic, tabular, scalenohedral, etc. [8]. On the other hand, according to the architectural definition, “habit” or “habitat” means home environment – a place in which to live according to the same laws and the same way of living, style of construction of houses etc. [9].

Both the crystallographic and architectural forms are based on the principles of symmetry. The law of the small, full numbers (rational intercepts) in crystallography and the law of perspective in architecture are essentially the same. In addition, the expansion of a construction, room by room, can be compared with the growth of the crystalline frame, unit cell by unit cell. The increasing abundance of the buildings especially in the metropolis resembles to the closed package in the crystallography. On the other hand Ching [10] explains the definitions of basic architectural elements such as point, line, line to plane, plane, and volume; how these elements can be organized by ordering principles such as axis, symmetry, hierarchy, rhythm, repetition and transformation [11].

Thus, we can find a lot of relations between crystallography and architecture because of the same background – Geometry. Geometry has played a critical role in the generation of architectural forms [11]. For many centuries, architecture found inspiration in Euclidean geometry and Euclidean shapes (bricks, boards), and it is no surprise that the buildings have Euclidean aspects [7]. Perhaps, the crystallography and architecture may have been a link of this chain: Geometry – Crystallography – Architecture.

From the crystallographer point of view below is present the evaluation of crystallographic forms that were probably used as architectural models through the main periods of the story of art (Fig. 5, 6, 7, 8, 9).



Fig. 5. Pyramids in Giza, year 2613-2563 before Christ.



Fig. 6. Herengracht 386



Fig. 8. The saints church, Earls Barton, Northamptonshire

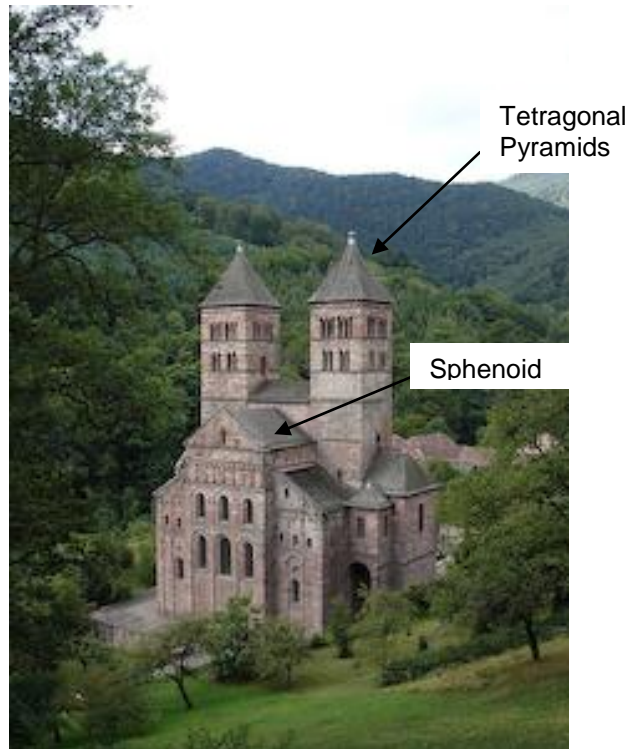

Fig. 9. Benectian church in Murbach, Alsace



Fig. 7. Pole houses, Rotterdam.

5. CONCLUSION

A strong relationship exists between crystallography and architecture, because of the same background – Geometry. The buildings have often forms that are similar or identical with simple or combined crystallographic forms, such as cub, tetragonal pyramid, tetragonal or hexagonal prism, etc. Making crystallography and making architecture means to shape the space. The Crystallography was probably a link of the chain: Geometry – Crystallography – Architecture. Crystallization is an architectural process made by nature.

7 REFERENCES

- [1] Dan Brown, 2003 – The code of Da Vinci.
- [2] Neil Leach, 199-Rethinking Architecture (Foucault Michel “ Of other Spaces Utopias & Heterotopias). A reader in cultural theory. London and New York (p. 348-356).
- [3] Keith Frye, 1993 – Mineral Science. An Introductory Survey.
- [4] Michel Lincourt, 1999 – In search of elegance. Towards an architecture of satisfaction. Liverpool University Press.
- [5] Jean-François Lyotard 1991, 1998 – Phenomenology. New York: State University of New York Press.
- [6] E. H. Gombrich, 1995 – The story of art.
- [7] N. Sala, 2004 – Complexity in architecture. International Conference on Design and Nature N°2, Rhodes, Greece (vol 6).
- [8] The wordsworth publishing, Dictionary of Science and Technology, Great Britain, 1996.
- [9] Bloomsbury publishing, Encarta Concise English Dictionary, London, 2001.
- [10] Ching Francis, 1979- Architecture: Form, space and order. Van Nostrand Reinhold Company.
- [11] Robert J. Krawczyk 1997- Hilbert's building blocks. Proceedings of Architecture Conference, 1997

YOUR, References: Should be set in template “References”. Tirana, 2012.

AUTHOR, Author: Title of the source. Paris, 2009.

BUTHOR, Author: Title of the source. London, 2009.

CUTHOR, Author: Title of the article. In: Title of the Periodical, Vol. 47, Issue 5, pp. 123-456. Los Angeles, 2009.

DUTHOR, Author: Title of the article. In: Title of the Periodical, Vol. 47, Issue 5, pp. 123-456. Madrid, 2009.