

DESIGN AND IMPLEMENTATION OF A CHATBOT FOR CUSTOMER SUPPORT

THESIS SUBMITTED TO  
THE FACULTY OF ARCHITECTURE AND ENGINEERING  
OF  
EPOKA UNIVERSITY

BY

MARVIN BILALI

IN PARTIAL FULFILMENT OF THE REQUIREMENTS  
FOR  
THE DEGREE OF MASTER OF SCIENCE  
IN  
ELECTRONICS AND COMMUNICATION ENGINEERING

MARCH 2023

DESIGN AND IMPLEMENTATION OF A CHATBOT FOR CUSTOMER SUPPORT

THESIS SUBMITTED TO  
THE FACULTY OF ARCHITECTURE AND ENGINEERING  
OF  
EPOKA UNIVERSITY

BY

MARVIN BILALI

IN PARTIAL FULFILMENT OF THE REQUIREMENTS  
FOR  
THE DEGREE OF MASTER OF SCIENCE  
IN  
ELECTRONICS AND COMMUNICATION ENGINEERING

MARCH 2023

## Approval sheet of the Thesis

This is to certify that we have read this thesis entitled “**Design and Implementation of a Chatbot for Customer Support!**” and that in our opinion it is fully adequate, in scope and quality, as a thesis for the degree of Master of Science.

---

Dr. Arban Uka  
Head of Department  
Date: March, 11, 2023

Examining Committee Members:

Prof. Dr. Betim Cico (Computer Engineering) \_\_\_\_\_

Dr. Arban Uka (Computer Engineering) \_\_\_\_\_

Dr. Florenc Skuka (Computer Engineering) \_\_\_\_\_

**I hereby declare that all information in this document has been obtained and presented in accordance with academic rules and ethical conduct. I also declare that, as required by these rules and conduct, I have fully cited and referenced all material and results that are not original to this work.**

Name Surname: Marvin Bilali

Signature: \_\_\_\_\_

## ABSTRACT

# DESIGN AND IMPLEMENTATION OF A CHATBOT FOR CUSTOMER SUPPORT

Bilali, Marvin

M.Sc., Department of Computer Engineering

Supervisor: Prof. Dr. Betim Cico

The number of companies encouraging use of chatbots as a substitute source for customer service is increasing more and more. Users must have confidence in chatbots giving them the assistance they need. But the confidence in chatbots by users is affected by the shortage of information in this aspect. Users' confidence in chatbots for customer service is thought to be affected (a) by factors related to the specific chatbot, mainly the quality of understanding of requests and advice, its similarity to man, his personal performance and appearance, and his profession, (b) by factors related to the kind of the service, the type of chatbot host, the security and privacy guaranteed by the chatbot, as well as general views of danger associated with the request's subject.

The content considers artificial intelligence as the area of computer science upon which computer systems, robotics, and customer support systems are built, the general perception of intelligence and how it is categorized.

Further on the content continues with the explanation of the idea of chatbots and studies in the sector of customer service, the difficulties, and benefits of using these systems, and also presents an example where a chatbot system was used in the area of customer support.

**Keywords:** Chatbots, Artificial Intelligence, customer service, chatting agent, Natural Language Processing, Neural Networks

## ABSTRAKT

### DIZENJIMI DHE IMPLEMENTIMI I NJE CHATBOT-I PER SHERBIMIN E KLIENTIT

Bilali, Marvin

Master Shkencor, Departamenti i Inxhinierise Kompjuterike

Udheheqesi: Prof. Dr. Betim Cico

Numri i kompanive që inkurajojnë përdorimin e chatboteve si burim zëvendësues për shërbimin ndaj klientëve po rritet gjithnjë e më shumë. Përdoruesit duhet të kenë besim në chatbotët që ua ofrojnë ndihmën që ata kanë nevojë. Por besimi i përdoruesve në chatbotët ndikohet nga mungesa e informacionit në këtë aspekt. Besimi i përdoruesve në chatbotët për shërbimin ndaj klientëve mendohet se ndikohet (a) nga faktorë të lidhur me chatbotën specifike, kryesisht cilësia e kuptimit të kërkesave dhe këshillave, ngjashmëria me njeriun, performanca dhe pamja personale, dhe profesioni i tij, (b) nga faktorë të lidhur me llojin e shërbimit, llojin e strehës së chatbotës, sigurinë dhe privatësinë e garantuar nga chatboti, si dhe pikëpamjet e përgjithshme të rrezikut të lidhur me temën e kërkesës.

Përmbajtja konsideron inteligjencën artificiale si fushën e shkencës së kompjuterave mbi të cilën ndërtohen sisteme kompjuterike, robotë dhe sisteme mbështetjeje ndaj klientëve, ndërsa konsiderohet dhe perceptimi i përgjithshëm i inteligjencës dhe kategorizimi i saj.

Më tej, përmbajtja vazhdon me shpjegimin e konceptit të chatboteve dhe studimeve në sektorin e shërbimit ndaj klientëve, vështirësitë dhe avantazhet e përdorimit të këtyre sistemave, dhe gjithashtu prezanton një shembull ku një sistem chatboti u përdor në fushën e mbështetjes ndaj klientëve.

**Fjalë kyçe:** Chatbotë, Inteligjencë Artificiale, shërbim ndaj klientëve, agent i bisedimit, Procesim i Gjuhës Natyrale, Rrjetat Neuronale.

## Table of Contents

Methodology .....	9
CHAPTER I.....	10
ARTIFICIAL INTELLIGENCE.....	10
1. Introduction.....	10
2. Artificial Intelligence .....	11
2.1 Features of Artificial Intelligence .....	13
2.2 What are the main areas that can contribute to Artificial Intelligence? .....	13
2.3 Programming using and without using artificial intelligence .....	14
3. Types of Artificial Intelligence .....	15
3.2 Type II: Based on functionality .....	16
4. Implementation through Artificial Intelligence .....	17
4.1 Natural Language Processing (NLP) .....	17
4.2 Vision.....	17
4.3 Autonomous Means .....	18
5. What is Intelligence?.....	18
5.1 Classification of artificial intelligence tasks .....	20
CHAPTER II.....	26
CHATBOT-S. CONCEPT OF THE CHATBOT SYSTEM.....	26
1. Chatbots .....	26
1.1 A brief history of chatbots .....	26
1.2 Study results.....	27
2. Conceiving a conversational agent .....	28
a. Word placement .....	29
b. Repetitive neural networks.....	30
3. Language identification.....	33
4. Purpose classification.....	34
5. Knowledge management.....	34
6. Generating responses .....	35
7. Performance evaluation.....	36
CHAPTER III .....	37
CHATBOT ARCHITECTURE .....	37
1. Software architecture .....	37

1.1	Agent environment.....	37
1.2	Class diagram.....	38
1.3	System modules .....	39
1.3.1	Purpose classification.....	39
1.3.2	Applicant for human intervention .....	39
1.3.3	Context Manager.....	39
1.3.4	Action Planner .....	39
1.3.5	Executor of the action .....	40
2.	Programming languages and libraries. Case Study: GAMMING1 chatbot .....	40
2.1	Data Extraction .....	41
2.2	Generating responses .....	43
2.3	Database generation .....	43
2.4	Pre-processing.....	44
CHAPTER III .....		45
CUSTOMER SERVICE SYSTEMS .....		45
1.	Introduction.....	45
2.	Automation in customer service .....	46
2.1	The concept of trust.....	46
2.2	Benefits of chatbots for customer service .....	47
2.3	Challenges of chatbots for customer service.....	47
2.4	Factors Affecting Trust in Chatbots for Customer Service.....	48
3.	Implications for the future design of customer service chatbots.....	50
CHAPTER IV .....		52
CHATBOT SYSTEM.....		52
	Introduction.....	52
	Conclusions.....	56
	Future Work .....	57
	References.....	58



## **Methodology**

According to Berndtsson et al. (2008: 13) there are two main classes of research methods, quantitative and qualitative. Quantitative methods usually focus on measuring things on numeric scales; however, they also consider the way something is constructed. On the other hand, Qualitative methods focus on increasing the understanding of the studied area, based on descriptive data, rather than producing an explanation for it.

For the preparation of this thesis, I have analyzed the scientific and professional articles I found in field of Artificial Intelligence and specifically of articles which were more focused on chatbot systems. This is considered as a Case study method. One of the cases studied is the example of GAMMING1 Chatbot that is mentioned below. In this thesis you will also find a practical design of a chatbot at the end.

To build the chatbot system in PHP, I studied about MySQL databases and tutorials in PHP.

# CHAPTER I

## ARTIFICIAL INTELLIGENCE

### 1. Introduction

The software agents known as chatbots interact with users in natural language. Correspondingly, they are considered as a potential tool for customer support. To ensure customer satisfaction, it is crucial for service providers to provide high-quality customer service.

In addition, client service, which typically involves personalized customer engagement, demands a lot of resources, including qualified customer service staff. Intelligent customer service automation can offer effective support while keeping expenses within reasonable limits. Given that customer service is more and more being offered through online chats, chatbots offer a possible technique for automating customer support. The technology of chatbots is not new. Nevertheless, new developments in artificial intelligence (AI) and machine learning, as well as the widespread use of messaging platforms, have urged businesses to consider chatbots as an additional component of customer care. Currently the use of chatbots in customer support is just one areas at the moment. Because of the broad application of innovative interactive solutions in various technological fields, user confidence is essential. Customer service is now one application of chatbot technology. From other areas of technology, as it is known user confidence is critical for a widespread use of new interactive solutions. Nonetheless, information about users' trust in chatbots and the factors that influence such trust are very limited. This is often a basic issue if the objective is to strengthen customer care through chatbots. Computer science has a branch called artificial intelligence (AI). The creation of software that performs activities that need human intelligence is known as artificial intelligence. The artificial intelligence procedures can deal with learning, perception, problem-solving, language comprehension, and/or logical reasoning.

## 2. Artificial Intelligence

Artificial intelligence (AI) is the process of making a computer even smarter than it is, or making a software think like a human being.

Artificial intelligence is produced by investigating how individuals learn, make decisions, and work to come up with a conclusion, and then using what will be found in the research as the starting point for the development of software and intelligent systems.

Machine learning is frequently considered as an example of "narrow" AI, constitutes the first concept in artificial intelligence. The general artificial intelligence is the second one, or the attempt to imitate human talents. Finally, Socio-Technical Convergent Systems are frequently referred to as Artificial Intelligence. [6]

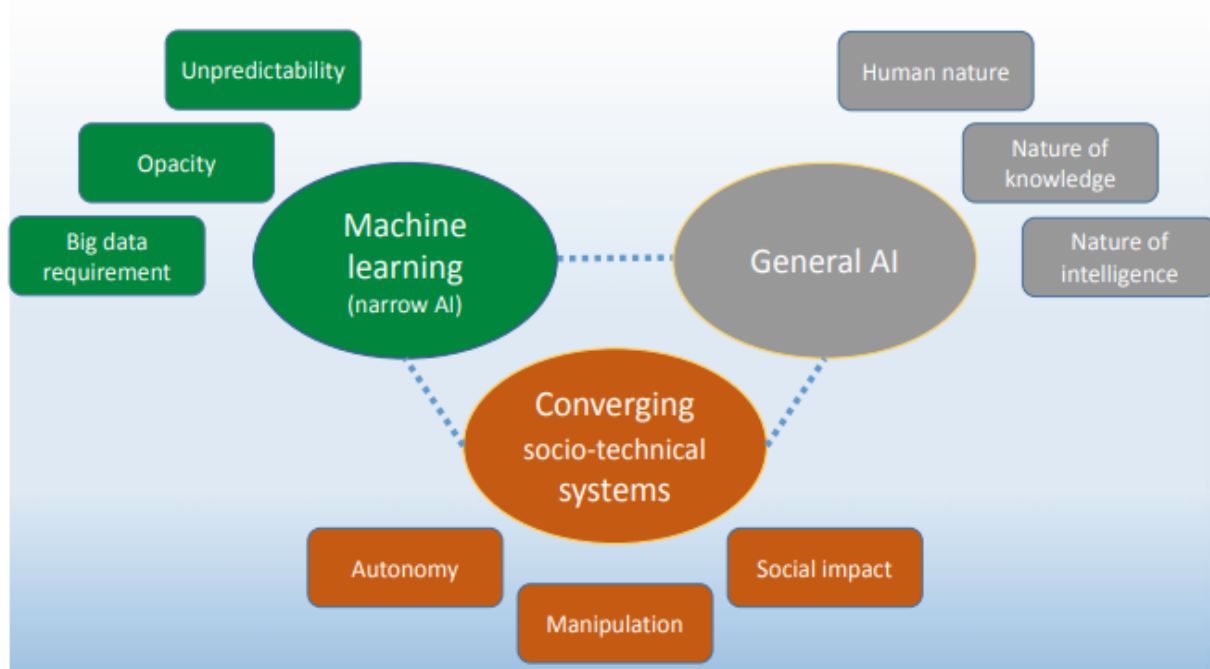

*Figure 1:* Features of using the term "Artificial Intelligence" [6]

Digital technologies are very workable and open to interpretation. They can be used for many intentions, and these intentions may not line up with the original idea, the one they were created for in the beginning. However, different Artificial Intelligence goals can be discerned that

essentially define the design, development, and use of systems. Here is a list of main goals: Artificial Intelligence for efficiency, Artificial Intelligence for social control and finally, Artificial Intelligence for human well-being. Artificial Intelligence can boost efficiency, which leads to cost reduction and thus to economic benefits. They will be interpreted to improve people's standard of living. [6]

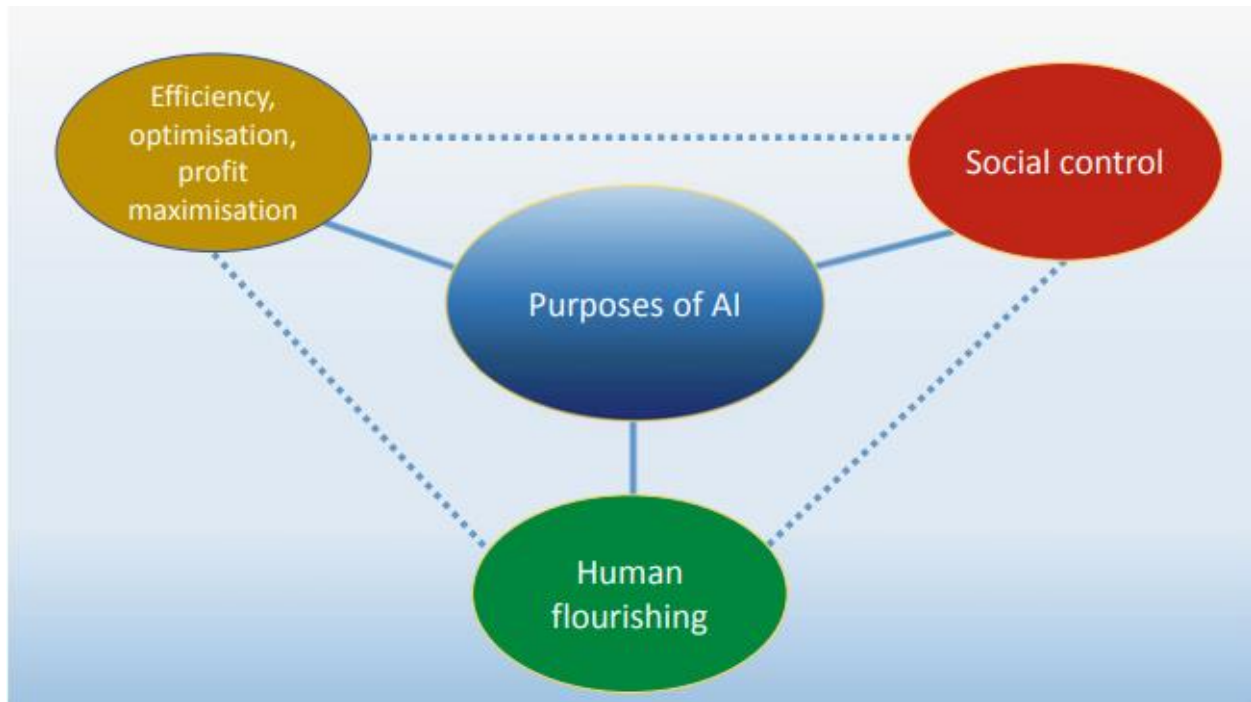

**Figure 2:** Possible Goals of Artificial Intelligence [6]

Artificial Intelligence is used in many ways, from personal assistants to vehicles with autopilot system. Artificial intelligence (AI) is evolving rapidly. While scientific research often defines artificial intelligence as robots as close to humans as possible, in fact Robotics is a branch of technology that deals with robots. A machine that executes a number of actions autonomously and in some cases semi-autonomously is what we call today a robot.

There are three key factors that make up a robot:

- a) Robots interact with the physical world through sensors.
- b) Robots are programmable.
- c) Robots are usually autonomous or semi-autonomous.

Robots have a different level of autonomy, some are "usually" autonomous, and of course there are some that are not autonomous. Telerobots, for instance, are entirely controlled by human operators, and in the same time they are classified as a branch of robotics. In conclusion, artificial intelligence robots are what connects robotics and AI together. Until recent years, all industrial robots were designed to perform a series of repetitive movements, and artificial intelligence was not necessary in this case. Non-intelligent robots are restricted in their purpose. Therefore, you need artificial intelligence algorithms in order to permit the robot to execute more compounded tasks.

## **2.1 Features of Artificial Intelligence**

Artificial Intelligence is design to use algorithms that detect patterns from large amounts of information and can boost human intelligence, impart knowledge, and improve productivity. Artificial Intelligence aims to use algorithms to build analytical models. Artificial intelligence technology is one of those who will discover how to accomplish tasks. Artificial Intelligence is a tool that grants the right to people to re-evaluate how we analyze data and consolidate information, and after that use that knowledge to make improved decisions.

## **2.2 What are the main areas that can contribute to Artificial Intelligence?**

Artificial Intelligence has in its foundations the following disciplines ie. Computer Science, Engineering Biology, Linguistics, Mathematics and Psychology. Developing functions that comprehend with human intelligence is the principal impetus of AI. Reasoning, learning, and problem solving are some of those functions. One or more areas from the following areas listed below can contribute to building an intelligent system: [5]

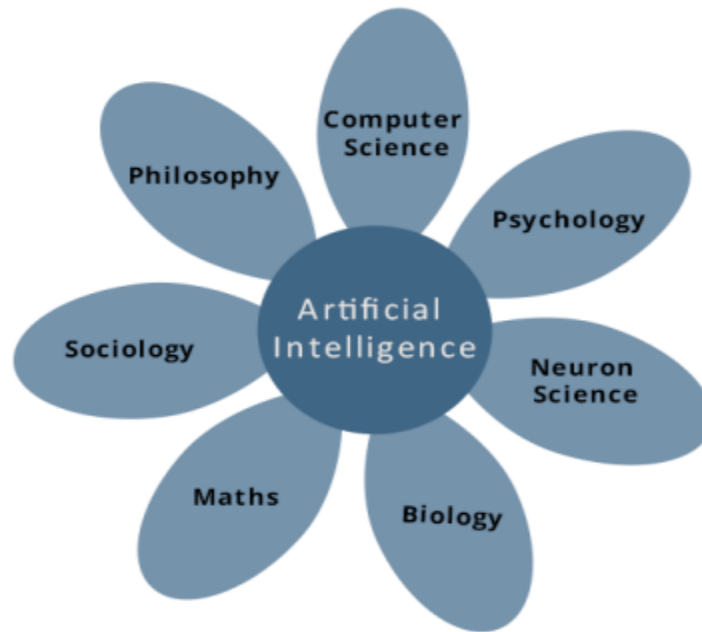

*Figure 3:* Areas contributing to Artificial Intelligence [5]

### **2.3 Programming using and without using artificial intelligence**

Programming using and without using artificial intelligence differs in the following ways:

#### **2.3.1 Programming without using artificial intelligence**

- A computer program can answer only specific questions, only the ones that it is intended to solve without the use of artificial intelligence.
- While you modify the program this leads to change of its structure.
- This modification can be neither easy nor fast, and may also lead to negative impact of the program.

#### **2.3.2 Programming using Artificial Intelligence**

- A computer program that uses artificial intelligence can answer general questions that are intended to be solved.
- You can perform new modifications of artificial intelligence programs by linking highly independent pieces of information together. Consequently, without affecting its structure, you can also modify some of the program information.
- Quick and easy program modification

### 3. Types of Artificial Intelligence

#### 3.1 Type I: Limited Artificial Intelligence

Today artificial intelligence is precisely known as limited AI. The latest is a non-sensitive machine intelligence, created to perform a restricted task (e.g., driving a car, or only face recognition, or just internet searches).

In researchers' perspective there is always a long-term goal. In this case it is to create an artificial intelligence (AGI) to be as smart as a human being. In other words, this would be a "computer" acting in different situations using intelligence and logic. It is known that limited AI can surpass humans in playing chess or solving equations. AGI would be the one to surpass humans in every task.

The ultimate hypothetical goal is to achieve super intelligence (ASI) which is far greater than that of the brightest and most talented human minds. Super intelligence is expected to be a rapid result of the creation of general artificial intelligence.

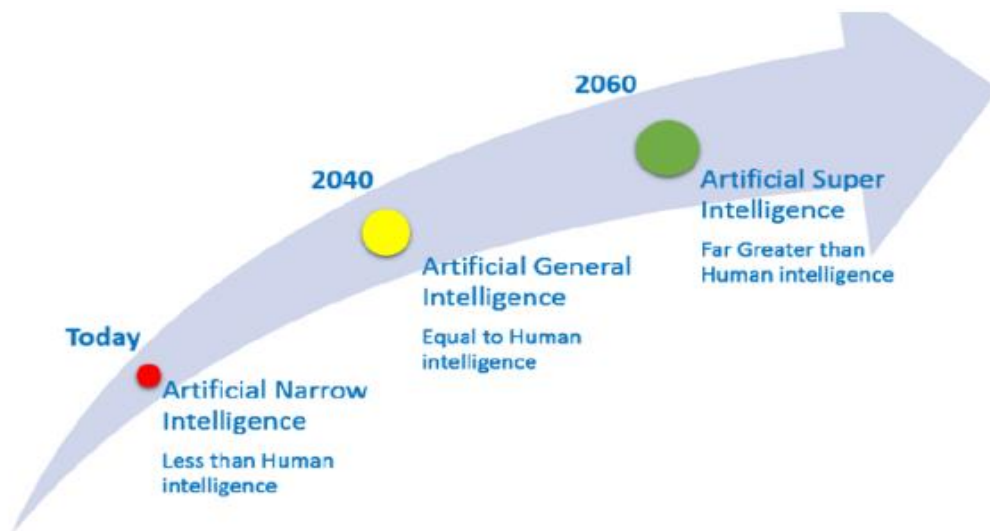

*Figure 4: The Future of Artificial Intelligence*

## **3.2 Type II: Based on functionality**

### **3.2.1 Reactive Machines**

Reactive machines are fundamental in the sense that they have no memory system, the way they function is by using experiences from the past in order to determine future actions. Reactive machines react based on their perception of the world. IBM Blue Deep, which defeated chess master Kasparov, is a jet machine that sees parts on a chessboard and reacts to them. Reactive machines can not refer to any of the previous experiences and definitely they cannot be improved with practice.

### **3.2.2 Limited memory**

Machines with limited memory system can store data for a short period of time. These machines make use of this data for a certain period, but this data is not added on the storage system of their experiences. Self-driving cars for e.g., use Limited Memory technology: they function based on the stored data that will be gathered based on the circumstances that will be created on the road.

### **3.2.3 Theory of Mind**

Based on psychology, people's behavior is driven by their thoughts, emotions, memories, and mental patterns. Mind Theorists hope to build computer systems that mimic our mental models, forming representations of the world and its agents and other entities. One of the goals that these researchers have is to develop computer systems that connect with humans and recognize intelligence and people's emotions. However, the computer that will use the "mind" instead of models doesn't exist.

### **3.2.4 Awareness**

Many AI fanatics believe that Conscious machines are the goal of AI. Machines can function just like a person does, for example by protecting itself, anticipating its own needs and requirements, connecting with others as equals, but can a machine be conscious just like a human being? This is a question left to philosophers to judge.



## 4. Implementation through Artificial Intelligence

There are numerous ways to apply Artificial Intelligence, as shown in the figure below:

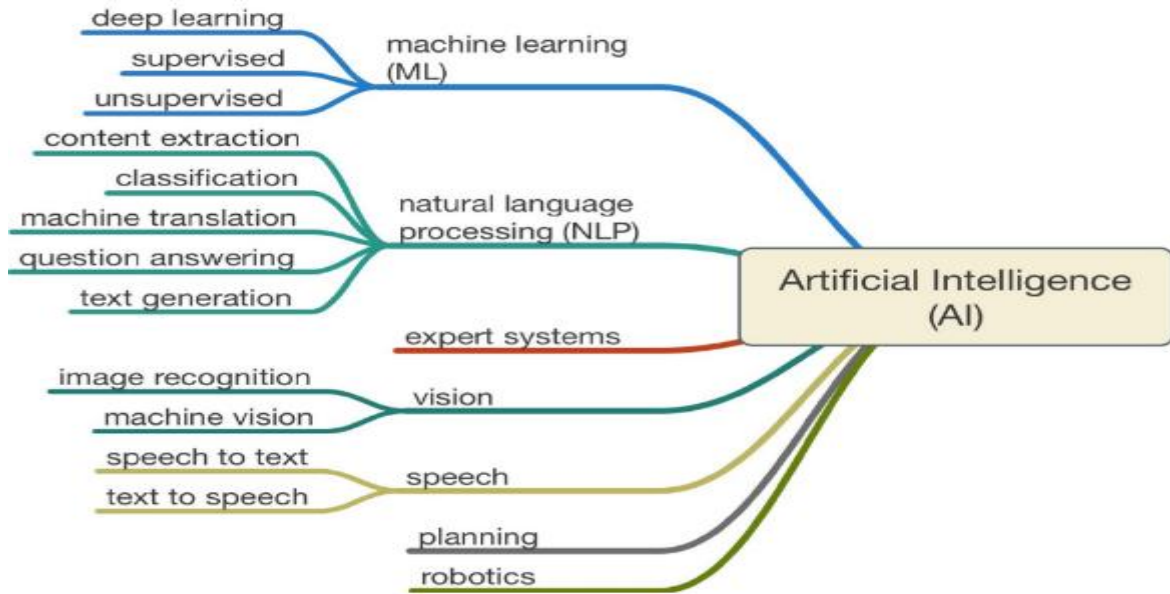

*Figure 5:* Branches of Artificial Intelligence

### 4.1 Natural Language Processing (NLP)

NLP is critical in enabling communication between humans and computers, and it has a wide range of applications in areas such as customer service, language translation, and social media analysis, among others. For example, NLP allows computers to comprehend text, listen to spoken words, understand them, analyze emotions and sentiments, and determine the relevant parts. In today's world, machines can analyze language-based information more effectively than humans, without becoming tired, and in a consistent and impartial manner.

### 4.2 Vision

Recently, advancements on the Internet of Things (IoT) have resulted in a reduction in the cost of acquiring and identifying big data sets. Currently, machine learning is more available for examination applications than it has ever been in the past. On the other hand, the other significant method of utilizing artificial intelligence in vision systems is to continuously enhance recognition applications.

### 4.3 Autonomous Means

Autonomous machines gather data from their surrounding environment and serve as an intelligent agent, making decisions in a sequential manner, enabling an autonomous vehicle to perform tasks in a similar environment. This forms a repetitive loop referred to as the perceptual activity cycle. The diagram below displays the autonomous flow of data for the vehicle.:

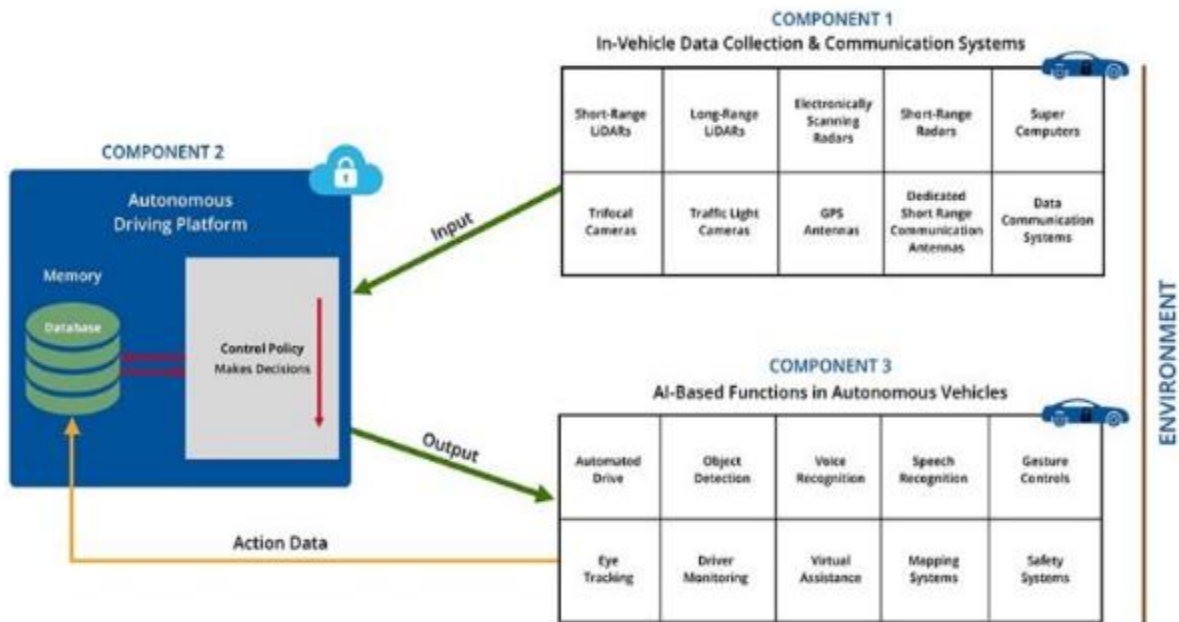
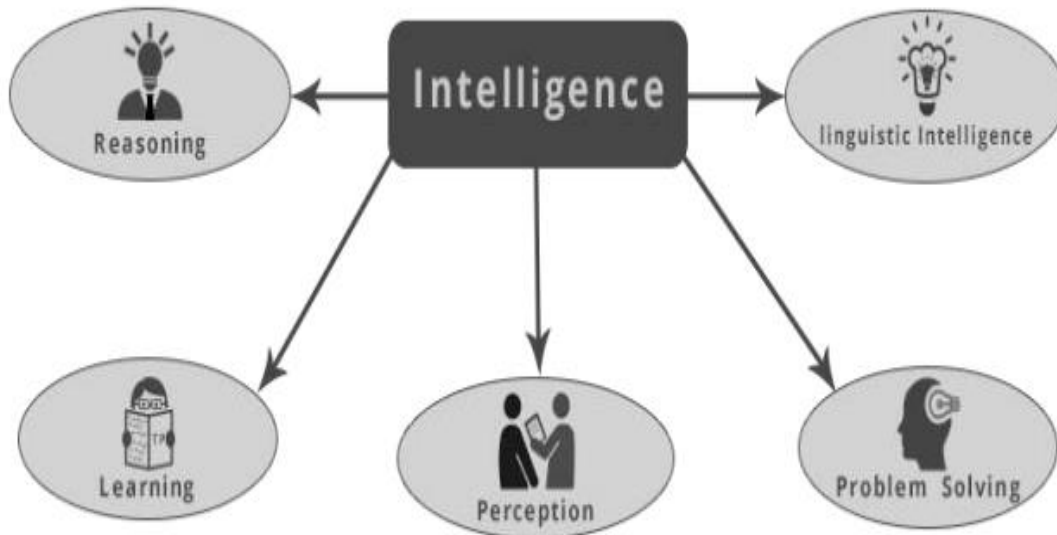

*Figure 6: The cycle of perception of Artificial Intelligence actions in autonomous machines*

## 5. What is Intelligence?

Currently, everyone is discussing Artificial Intelligence, which involves making a computer, robot, or software think and process information in a manner like how humans do. The development of Artificial Intelligence is based on researching the processes of human cognition and learning, including decision-making and problem-solving. This research forms the foundation for creating software and intelligent systems that mimic human thinking. Intelligence refers to the capacity of a system to perform tasks such as calculation, reasoning, recall, perception of patterns, learning from experience, problem-solving, comprehension of complex concepts, fluid usage of natural language, categorization, generalization, and adaptation to new situations. Intelligence is an innate characteristic and encompasses a wide range of abilities: [5]

- a) Reasoning
- b) Learning
- c) Problem solving
- d) Perception
- e) Linguistic Intelligence



*Figure 7: Components of Intelligence [5]*

- Reasoning: Reasoning is defined as the set of logical processes that lay the foundations for judgment, decision-making and forecasting. Reasoning is divided into two categories:
  - Inductive reasoning: to make general statements it needs to conduct specific observations.
  - Deductive reasoning: to reach a specific and/or logical conclusion, it needs to start with a general statement.
- Learning: Acquiring knowledge or skills through studying, practicing, experiencing, or other forms of exposure is what is known as learning. This process increases one's understanding and familiarity with the subject being studied.
- Problem solving: Problem solving means the perceived process and the attempt to achieve the desired result by following certain steps that may be hindered by known or unknown elements. Problem-solving encompasses the act of making choices, which involves choosing the best option from multiple possibilities to attain the desired outcome.

- Perception: The process of acquiring, interpreting, evaluating, and arranging information is known as perception. It requires sensitivity and a keen sense of awareness. In the context of AI, the perception mechanism integrates the data collected by sensors and presents it in a coherent manner.
- Linguistic intelligence: Linguistic intelligence refers to the capacity to effectively communicate through speech and written language, including the ability to understand and use words effectively in conversation. This type of intelligence plays a crucial role in effective communication and interaction.

## 5.1 Classification of artificial intelligence tasks

The field of artificial intelligence is classified into official tasks, common tasks, and expert tasks: [5]

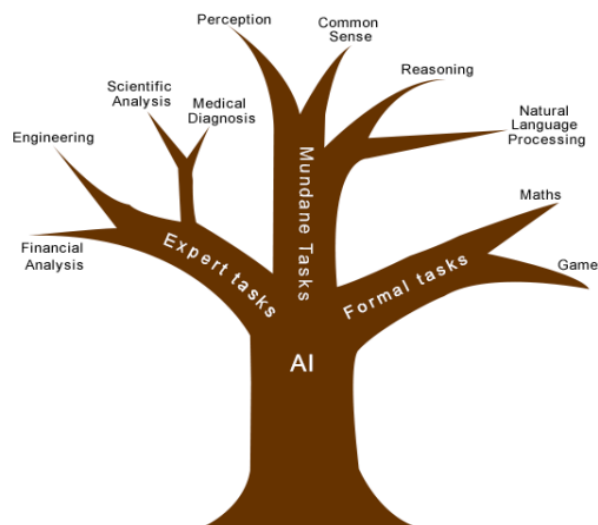

From a young age, individuals acquire knowledge through various means such as observation, speech, language, and their senses. They then proceed to learn the duties and responsibilities of everyday life, followed by the more specialized skills of experts in a particular field.

Humans have an innate ability to learn everyday tasks with ease. This same notion was assumed to be true before the attempt to replicate these tasks in machines was made. Previously, the responsibility of artificial intelligence was focused on the field of common tasks. Later, it turned out that machines require more knowledge, complex knowledge representation, and complex algorithms for handling common tasks. Therefore, the field of artificial intelligence is making more

progress in the development of expert systems. Expert systems require specialized knowledge and not just general understanding, which makes it easier to represent and manage in comparison.

Expert systems are computer programs designed to tackle intricate issues in a specific domain, with the intelligence and proficiency of a human expert.

### **Characteristics of Expert Systems**

- Performance High performance
- Understandable
- Trusted
- Very responsible

### **Expert systems skills**

#### **Expert systems can:**

- Advise
- Guide and assist people in decision making
- Demonstration
- Offering a solution
- Diagnosis
- Explanation
- Interpretation of data
- Prediction of results
- Reasoning for termination
- Suggesting other options for a problem

#### **They are incapable of:**

- Replacement of human decision makers
- Mastery of human skills
- Producing accurate results for insufficient knowledge base
- Improving their knowledge

### 5.1.2 Components of Expert Systems

Expert Systems components include:

- a) Based on knowledge
- b) Inference Engine
- c) User interface

[5]

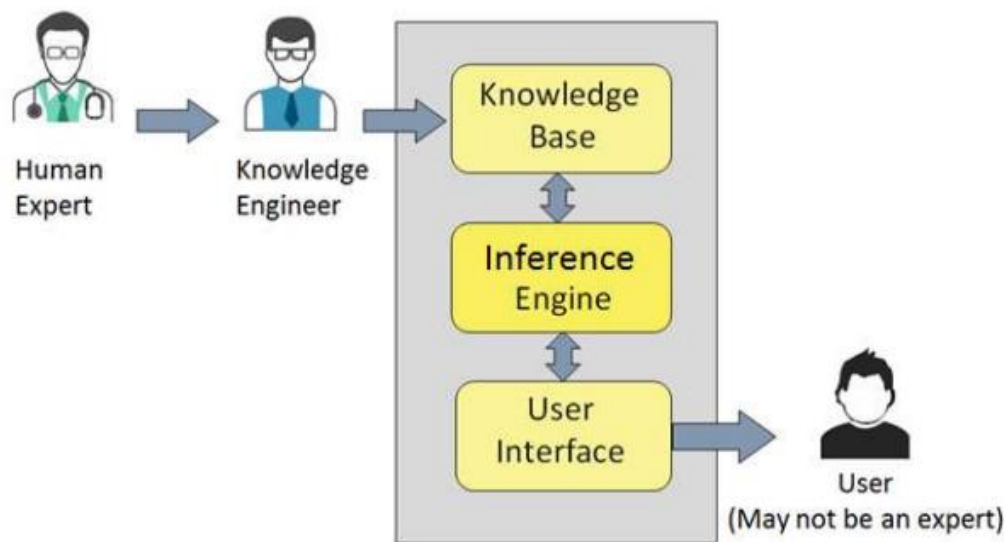

#### 5.1.2.1 Knowledge base

An expert system is comprised of specialized and top-notch information. To demonstrate smarts, it's crucial to have a strong grasp of the knowledge. The success of an expert system is directly proportional to the quality and precision of the information gathered. The more trustworthy and precise the data, the more effective the system will be.

What is Knowledge? The collection of facts (numbers, words etc.) brings the data. The information is structured as a collection of details and facts related to a particular area of endeavor. While knowledge combines not only data and information but also experience.

#### 5.1.2.2 Inference Engine

Achieving a correct and error-free solution requires utilizing efficient methods and rules from the Inference Engine. The Inference Engine in knowledge-based expert systems operates by

processing and utilizing information from the knowledge base to reach a definitive outcome. In the case of rule-based expert systems, it:

- Applies rules repeatedly based on the outcome of previous rule applications, using the facts obtained from these applications.
- If necessary, adds fresh information to the existing pool of knowledge in the knowledge base.
- Resolves any conflicting rules that may arise when multiple rules are relevant to a specific scenario.

The following strategies are used by the inference engine to recommend a solution: [5]

- Forward Chaining
- Backward Chaining

- **Forward Chaining**

"What can happen next?" is a common question which needs the strategy of an expert system to answer it. Here, the inertia of the angina follows the chain of conditions and consequences and finally draws the conclusion. Therefore, all the facts and rules will be taken into consideration and will be listed before coming up with a solution. The strategy followed is about to conclude, result or effect. For instance, forecasting stock market status as an effect of changes in interest rates.

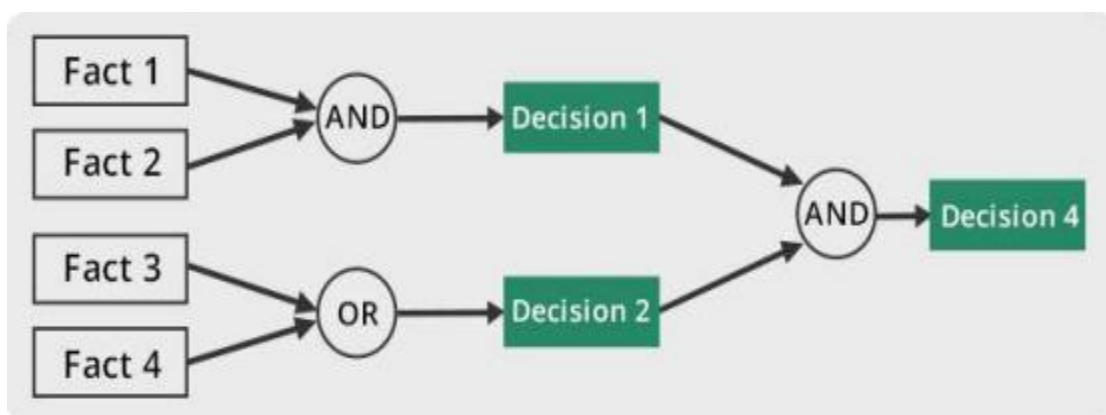

*Figure 8: Forward Chaining [5]*

- **Backward Chaining**

"Why did this happen?" is another common question which needs backward chaining strategy through an expert system to find the answer. The inference engine attempts to determine the underlying conditions that could have led to a particular outcome, based on prior events and information. This approach is used to identify the underlying cause or explanation. For instance, the diagnosis of blood cancer in humans.

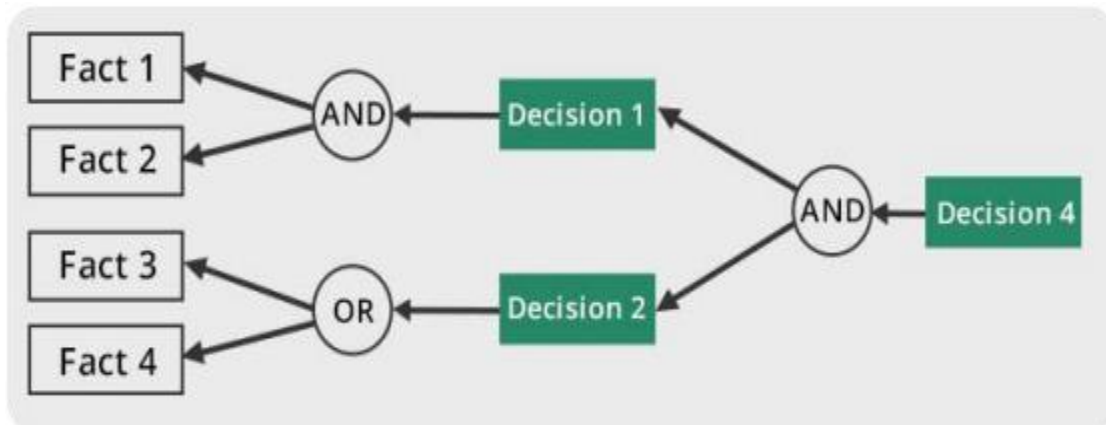

*Figure 9: Backward Chaining [5]*

### 5.1.2.3 User interface

Between the Expert System user and the Expert System itself there is the user interface that guarantees interaction. Natural Language Processing is generally used by a proficient user in the field of tasks. It's not a requirement for the user of an expert system to possess extensive knowledge in artificial intelligence. He should be able to explain and understand how the Expert System has reached a specific direction.

The explanation can be in the following forms:

- Natural language displayed on the screen
- Verbal results in the form of Natural Language
- List of rule numbers on the screen.

The user interface provides a way to monitor the validity of deductions made by the system. The criteria that an Expert System must meet to be effective are:

- Must help users to achieve their goals in a very short time, the shortest possible.



- Must be designed to work on previous work practices or desired user.
- The technology employed in the system should align with the user's needs, rather than forcing the user to adapt to the technology.
- Must use user data efficiently

### **5.1.3 Limitations of Expert Systems**

Developing comprehensive and straightforward solutions using technology can be challenging, as large-scale systems are both time-consuming to build and require significant computing power, making them both costly and resource intensive. Expert Systems has the following limitations:

- Limitations of technology
- Acquisition of knowledge with difficulty
- Maintaining expert systems can be a challenging task.
- Have high development costs

### **5.1.4 Benefits of Expert Systems**

- Availability: The wide-scale production of software has made Expert Systems readily available and easily accessible.
- Have low production costs: Production costs are reasonable. This makes these systems affordable.
- Speed: Provide high speeds and decrease the amount of work done by an individual.
- Have a low error rate: the error rate is low if you compare it to human errors.
- Risk reduction: They can work in an environment that is dangerous to humans.
- Consistent response: Expert Systems work consistently without becoming emotional, tense or tired.

## **CHAPTER II**

### **CHATBOT-S. CONCEPT OF THE CHATBOT SYSTEM**

#### **1. Chatbots**

Chatbot is a software program used especially on the Internet and is designed to simulate conversation with human users. Formally they are referred to as chat agents, in the scientific literature. They facilitate interaction with data and services through natural language and are considered to be machine representatives. Even though the term chatbot is relatively new, literature tells us that since the 1960s, researchers and developers have created and studied computer systems known as chatbots, which allow for natural language interaction with users. The recent surge in interest in chatbots can be attributed, in part, to recent advancements in artificial intelligence and machine learning. The use of chatbots shows promise in various fields, including information services, education, therapy, and customer service.

A recent examination of customer service chatbots revealed that the emotional and physical condition of the customer greatly impacts their interactions with the chatbots.

Artificial intelligence-powered chatbots, with their ability to detect emotions through machine learning, have the potential to recognize and respond to a client's emotional state in a manner similar to human operators. However, there is limited understanding of user trust in chatbots, which is a crucial element in obtaining user engagement with interactive systems. This represents a significant knowledge gap.

#### **1.1 A brief history of chatbots**

The first chatbot, ELIZA, was introduced in 1966 and used basic natural language processing techniques to simulate a conversation with a psychiatrist. Although it was relatively simple, ELIZA was able to give the appearance of understanding the user's issues. The program successfully "tricked" many people. The creator of the program, Joseph Weizenbaum, mentioned also that his secretary wanted to personally have a private conversation with ELIZA. Following in the footsteps of

ELIZA, chatbots evolved over time by incorporating new technologies and features such as speech synthesis and emotion recognition. One notable example is SmarterChild, which was developed by ActiveBuddy, Inc. (now Colloquis) and became available on AOL Instant Messenger and MSN Messenger in 2001. The creation of SmarterChild marked a significant moment in the evolution of chatbots, as it was designed to be used on instant messaging platforms and provided users with quick access to various types of information. It connected to a knowledge base and was equipped with useful information for users. However, due to the limitations of natural language processing technology at the time, this chatbot, along with many others, has been forgotten by history.

Another major breakthrough in the field of chatbots was made by the team at IBM through their Watson AI project. Since 2006, it is still being developed. The chat agent was created with the intention of claiming a price in an American television show! They were able to win the price competing against two former champions.

The interesting fact is that from the perspective of NLP as the questions imply a lot of puns and quick retrieval of information is needed, especially on an enormous knowledge base. Unfortunately, in its past, AI could only reply to one-line questions and could not continue an appropriate conversation with anybody. In the early 2010s, virtual assistants like Siri, Cortana, Google Assistant, and Alexa emerged, bringing the concept of conversational and goal-oriented dialogue to the forefront. A major turning point in the field occurred in 2016 with the introduction of the Messenger Platform for Facebook Messenger, which enabled non-AI affiliated companies to create chatbots.

## **1.2 Study results**

User preferences, and especially the ones regarding customer service, have been taking into consideration by several studies. A recent study conducted by Drift in partnership with SurveyMonkey Audience, Salesforce and myclever aimed to gauge customer perception of chatbots. The findings from the survey are summarized of the figure below:[8]

- According to the survey, a significant portion of customers face difficulties with traditional online communication methods. Specifically, 34% report difficulty in navigating websites and 31% report being unable to find answers to simple questions through these channels.

- Clients have identified several potential advantages of chatbot services, including: 24/7 availability (64%), rapid responses (55%), and the ability to receive answers to straightforward questions (55%).

Undoubtedly customer needs and expectations are higher than the ones previously met by traditional channels. They even see that compared to other solutions chatbots are more beneficial.

Despite the perceived benefits, clients still feel that chatbots have room for improvement. A survey by Chatbots.org found that 53% of customers across all age groups view chatbots as either "inefficient" or only "moderately effective." There appears to be a gap between the potential advantages of chatbots and their actual performance. The survey results also indicate a generational divide in customers' perceptions of chatbots. Younger, more technologically adept individuals tend to hold a more positive view of these digital agents. The study found that 56% and 54% of millennials and the Z generation, respectively, rated chatbots as "effective" or "highly effective." In contrast, the silent generation gave similar ratings to chatbots only 38% and 49% of the time, respectively.

## **2. Conceiving a conversational agent**

Conceptually, a chatbot consists of numerous elements that work simultaneously to achieve a common goal. Figure 10 summarizes visually the relationship between each part of a talking agent. When a new message is received, it undergoes initial processing by the language identification module. This may involve simple labeling or more complex statistical methods. The new message, along with the determined language and any relevant previous conversational messages from the backend, are then sent to the target classification module. The target classification module's task is to determine the user's intended goal from the new message. Using the message metadata, the identified purpose, and other information from the backend, it decides on the most appropriate action or series of actions. For instance, if the user's purpose is unclear, the chatbot may respond with an answer. On the other hand, if the user wants to reactivate their account, the chatbot might initiate the account reactivation process.

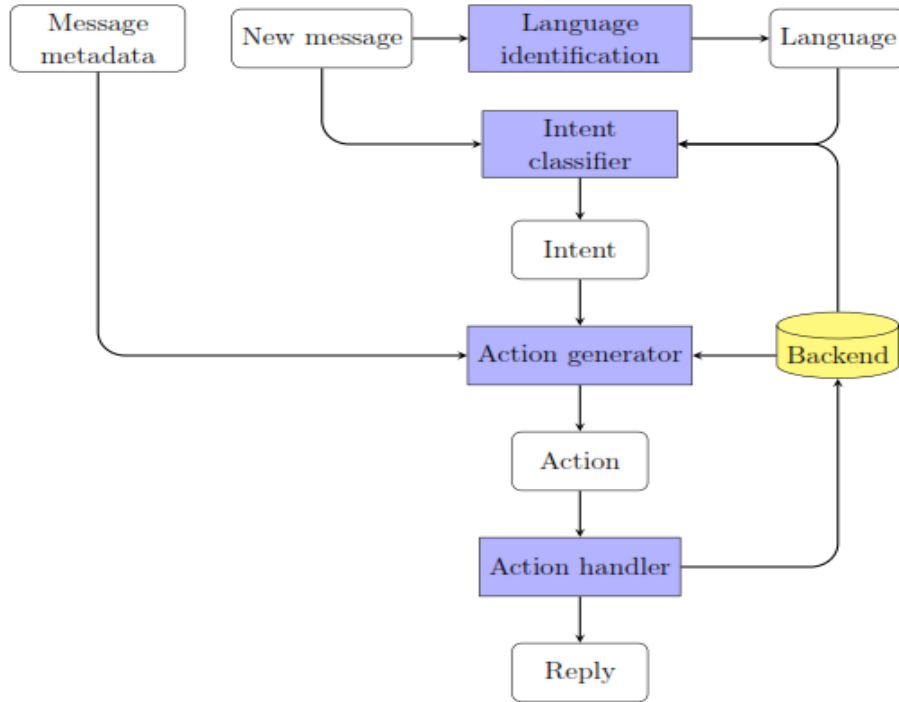

Figure 10: Schematic representation of the chatbot [8]

The final step is carried out by the action management module, which receives the decided action and executes it accordingly. This implementation has the advantage of being adaptable to different environments. Depending on whether the bot operates on a messaging platform or a company website, the execution of a single action can vary greatly.

### a. Word placement

Briefly, representing words as vectors simply involves positioning the words. This vector form can then be utilized as a feature in machine learning models. There are multiple methods for accomplishing this, starting with a straightforward counting vector, and extending to more advanced approaches such as Word2vec and GloVe. The latter has been demonstrated to be effective in conversational agent applications, with the skip-gram model being utilized in the implementation of layers in the Keras library.

**i. Skip-gram model**

The underlying concept of the skip-gram model is straightforward and it was first proposed in the publication "Essential Estimation of Word Representations in Vector Space." The model consists of a neural network with a single, fixed-size hidden layer that aims to predict a word's context. A diagram of the skip-gram model's structure is shown in Figure 11.



*Figure 11: Skip-gram model in the case of using 5 words*

The core idea remains unchanged despite the changing definitions of context: a fixed-sliding window is applied to the sequence of words, with the target word at its center, and the preceding and following words serving as its context. The extraction of the middle layer and its use as a vector representation is crucial for training the vocabulary. If the input words are encoded using a one-hot representation, it simply serves as a lookup table for the vector representations. The sequences and index sequences are eventually transformed into vector sequences for training the final algorithm.

**b. Repetitive neural networks**

Repeat Neural Networks (RNNs) are neural networks that are specifically designed to work with sequential data. They can be thought of as neural networks with nodes that maintain an internal

state, often referred to as  $C$  at time  $t$ , which is fed back into the node as input for the next time step and produces an output at each time step. However, using straightforward RNNs can result in a phenomenon known as the "Missing Gradient Problem," which has been documented by researchers Pascanu, Mikolov, and Bengio in their paper "Understanding the Missing Gradient Problem." To overcome this issue, various modifications to RNNs have been proposed, each employing different methods to address the problem. The most popular are:

**i. Long-Short-Term Memory Units**

Long-Short-Term Memory Units (LSTMs) have become a staple in Natural Language Processing, having first been introduced by Hochreiter and Schmidhuber in 1997. With the recent advancements in deep learning hardware, LSTMs have seen a surge in popularity in recent years. They have played a significant role in areas such as machine translation and image captioning. A depiction of an LSTM layer can be found in Figure 12.

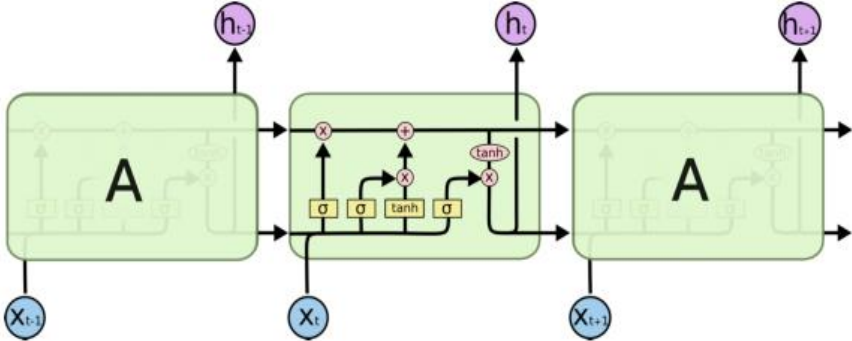

Figure 12: Example of the LSTM layer consisting of 3 elements [12]

An LSTM unit is composed of four primary components: the forget gate, input gate, cell state, and output gate. Given an input sequence  $x = (x_0, x_1, x_2, \dots, x_T) T$ , and the hidden state  $h = (h_0, h_1, h_2, \dots, h_T) T$  generated by the LSTM layer, the relationship between  $x$  and  $h$  can be represented by the following set of equations.

$$f_t = \sigma(W_f \cdot [h_{t-1}, x_t] + b_f) \quad (2.1)$$

$$i_t = \sigma(W_i \cdot [h_{t-1}, x_t] + b_i) \quad (2.2)$$

$$C_t = f_t C_{t-1} + i_t \tanh(W_C \cdot [h_{t-1}, x_t] + b_C) \quad (2.3)$$

$$o_t = \sigma(W_o \cdot [h_{t-1}, x_t] + b_o) \quad (2.4)$$

$$h_t = o_t \tanh(C_t) \quad (2.5)$$

Equation 2.1 represents the output of the forget gate. Essentially, it determines the information that the LSTM unit will retain or discard from the previous state of the cell state (C) by performing a direct multiplication with it. This process is depicted in Figure 13.

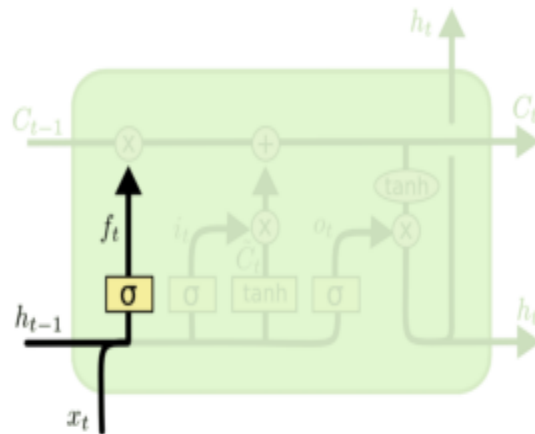

Figure 13: Forget gate in LSTM [13]

The output of the input gate is represented by equation 2.2. It generates a candidate value for the current cell state (Ct), which is then scaled as depicted in Figure 14.

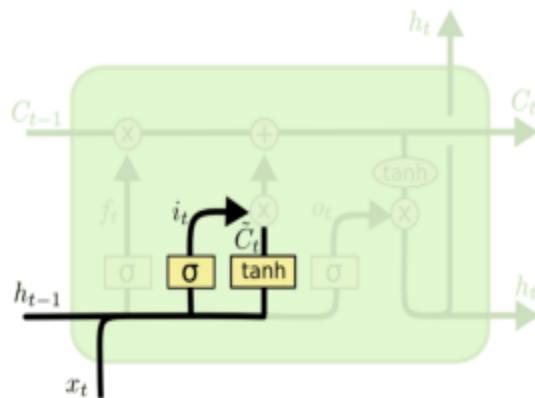

Figure 14: LSTM system input port [14]



The cell state is then updated as per equation 2.3, which takes into account both the forget gate and input gate. The relevant connections for this update are depicted in Figure 15.

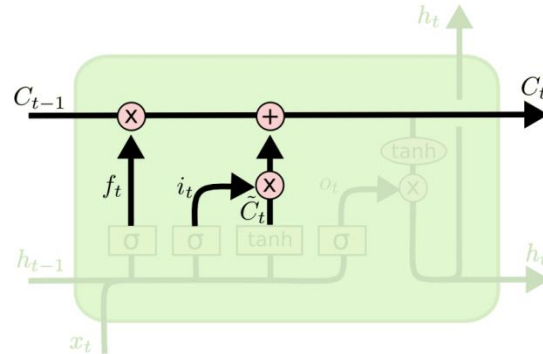

Figure 15: Update of LSTM cell status [15]

With the cell state updated, equation 2.4 can be used to determine the activation of the output gate and generate the hidden state of the LSTM unit, as illustrated in Figure 16.

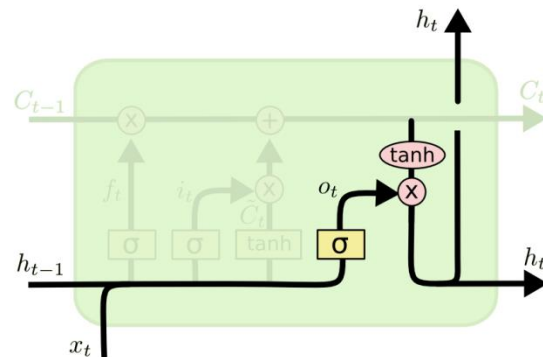

Figure 16: LSTM exit port [16]

### 3. Language identification

The identification of the language used in a text can be a crucial initial step in a broader natural language processing process. Some languages even contain homographs (words that exist in multiple languages with different meanings), making algorithms more complex when trying to

define these specific words. Thus, it becomes necessary to identify the language in a text before proceeding with further processing to enhance the accuracy of the results.

#### **4. Purpose classification**

When receiving a new message, the chat agent should be able to determine the intention or goal of the user. This is modeled as a multi-classification task, where the possible targets the user may have are labeled and classified. Methods to resolve this problem differ from simply extracting keywords into the Bayesian term in order to discover user demand established on multiple messages. LSTM networks have been familiar before because they are very suitable for this field.

#### **5. Knowledge management**

An intelligent agent cannot do considerably without knowledge. During 1980s under the name of knowledge engineering brought significantly improvement in the field of allowing computers to handle knowledge. In the past, inferring information was often accomplished through the use of an inference engine that utilized logic, both first and second order, to manipulate available data and uncover new insights. This method of finding answers to incomplete questions can often be easily translated into API calls and is useful in conversational agents and knowledge engineering for tasks such as answering basic factual questions. Examples of this include Siri and Amazon Alexa, which use internal knowledge inference techniques to gather information from the web and other sources.

## 6. Generating responses

To have a conversation, a conversational agent must have the capability to respond. Furthermore, the answers should be logical in accordance with the context of the dialogue. This issue can be resolved by utilizing two distinct modules that work in tandem: one generates a list of potential answers while the other selects the most appropriate or arranges them based on a specific criterion. Two recognized approaches have emerged from this subproblem: retrieval-based methods and generative-based methods. Retrieval-based methods rely on a vast database of possible responses and use information from the user's input to determine the most relevant response. This information may be a simple regular expression that requires a specific sentence structure, or it may come from a machine learning model. The advantage of this method is that the chatbot administrators have control over the responses, thereby avoiding any inappropriate answers.

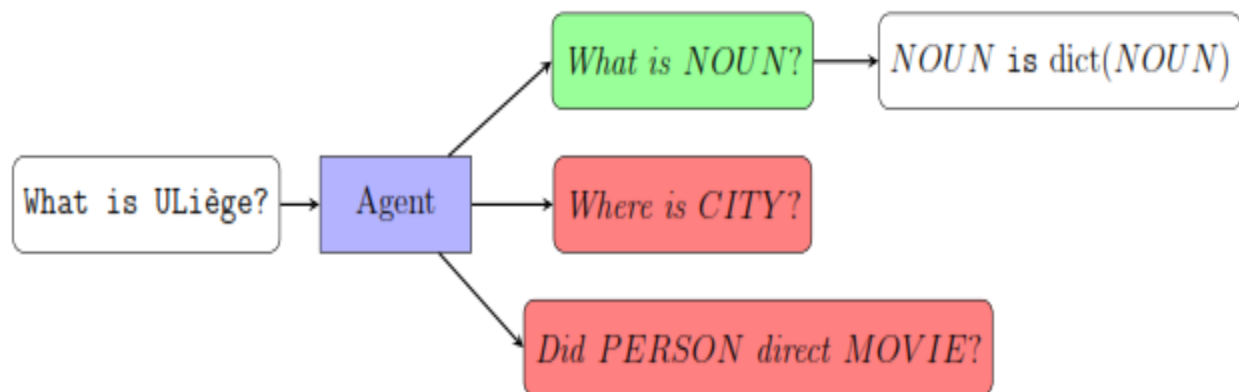

*Figure 17:* A toy-based example where the user's question matched a simple, green rule, which triggers the corresponding answer.

Generative-based techniques additionally depend on generating models to generate new responses without needing a wide-ranging database of examples. New answers can be easily created providing that the model is trained correctly. Nevertheless, today, the performance of generation-based methods is inadequate in relation to company constraints and the industry is still not convinced of its potential.



*Figure 18:* An example of generating responses based on toy generations

Modern developments have aimed to develop hybrid solutions where responses are generated if they cannot be obtained.

## **7. Performance evaluation**

Assessing the performance and metrics for measuring the effectiveness of a chatbot's behavior is a crucial area that needs improvement in the field of chat agents. A recent study of unsupervised evaluation metrics for generating conversational responses highlighted the disparity between standard metrics and intuitive human judgment. The fundamental issue is that speech and fluency are inherently subjective, making it challenging to quantify, as is the case with any other subjective aspect of a system.

# CHAPTER III

## CHATBOT ARCHITECTURE

### 1. Software architecture

#### 1.1 Agent environment

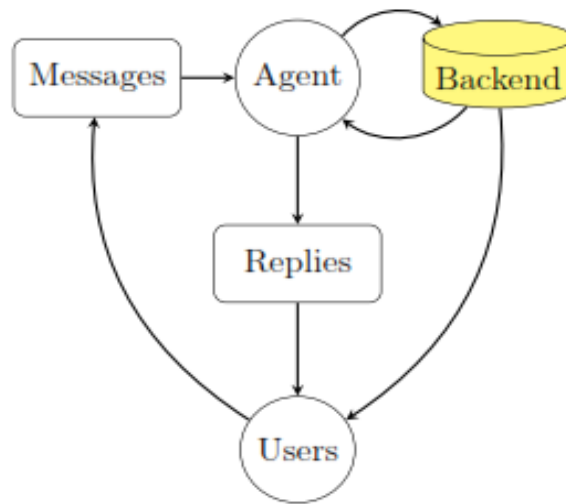

Figure 19: Agent median model [8]

The agent environment consists of several components, one of which is user messages. These messages are a source of dynamic information that the agent can receive at any moment. They include a string representing the actual text sent by the user, and a metadata structure that provides additional information such as a link to the conversation structure to which the message belongs, the time it was sent, the platform it was sent on, etc. The chatbot can only read the input and does not have the ability to modify it. Another significant aspect of the environment that the agent has access to is the company's backend, which holds more information about the user and the state of the database. The agent can access and potentially manipulate certain aspects of the backend. The chatbot also has the ability to respond to users in order to receive new information or confirm that

their request has been received and handled appropriately. A visual representation of the agent environment is depicted in Figure 19.

## 1.2 Class diagram

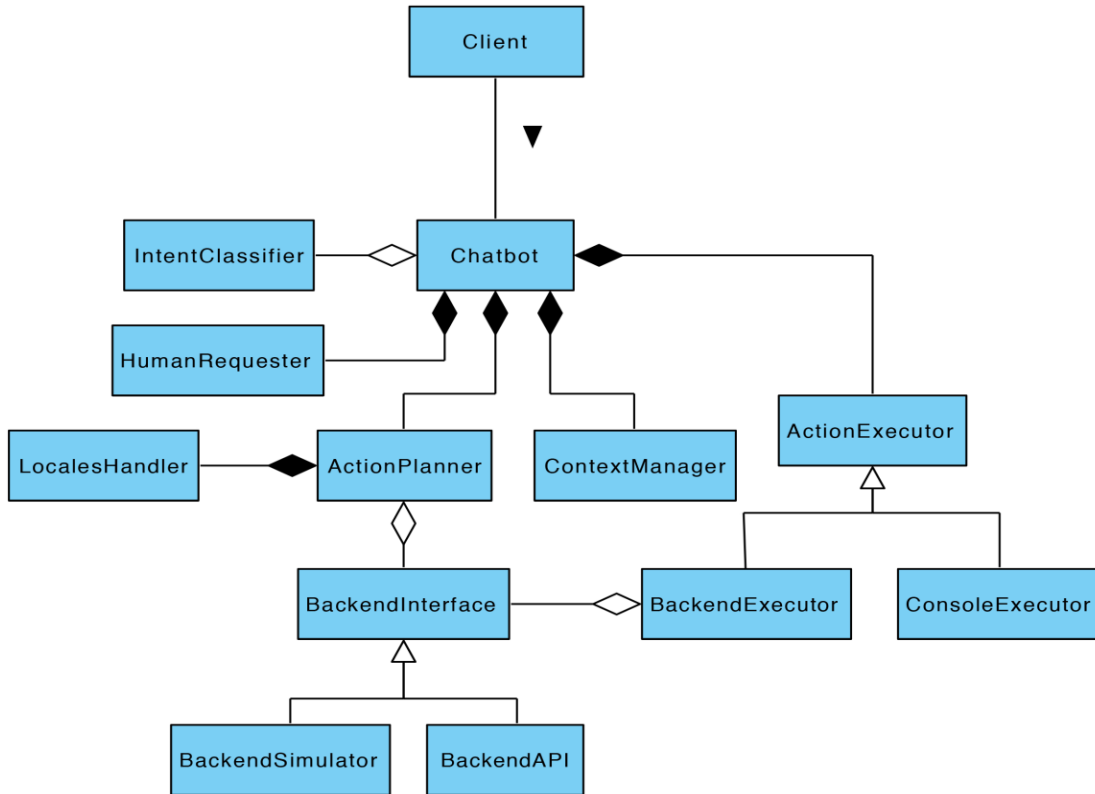

Figure 20: Chatbot class diagram [8]

This diagram shows clearly that, the chatbot consists of various components and each of them solves a specific issue. The Client component, labeled at the top, is a general client program that utilizes the chatbot. It can be a simple client terminal or a more sophisticated dynamic online listener that retrieves new tickets as they are issued through the system. The chatbot consists of five main components: IntentClassifier, HumanRequester, ActionPlanner, ContextManager, and ActionExecutor. It is also illustrated that the ActionPlanner has access to two sub-modules, with one of them (BackendInterface) being shared with another sub-module.

## **1.3 System modules**

### **1.3.1 Purpose classification**

This module demonstrates how to identify the user's intention based on a message. It employs various neural networks to carry out its operations. The module takes a single input, which is a standalone user message, and produces an output in the form of a dictionary that lists each user's intention along with its corresponding probability for that message.

### **1.3.2 Applicant for human intervention**

This component operates immediately after goal classification. Its role is to require the involvement of a service agent, a human customer, in case the user's input cannot be accurately identified. It is offered as a component because it makes the process of switching between behaviors uncomplicated and trouble-free (For example, one might want a more conservative chatbot when dealing with high profile clients who will more often require human intervention). The context of a dialogue may be hidden in the entire conversation with a user, as provided by the context manager. The outcome in the backend is simply a Boolean value indicating that, based on the context, the module deems human intervention to be necessary.

### **1.3.3 Context Manager**

This component is responsible for organizing the environment's structure. In this context, an environment refers to the arrangement of messages along with the accompanying metadata. These elements help users resolve specific issues, which aligns with our intuitive understanding of a single conversation.

### **1.3.4 Action Planner**

Having a probability vector is the intention of the action planner so it can decide the action agents should take. It is liable for monitoring the condition of the backend and creates a load that contains the actions that will be executed and the order of them. As a result, the loading format will be a straightforward JSON object. This component is also responsible for constructing the actual

response that will be sent to the user. It utilizes two sub-modules: the premise holder and the backend interface.

#### **1.3.4.1 Local therapists**

This component is the central hub for all localization-related activities. Inspired by the Chrome i18n infrastructure for browser extensions, it offers a unified interface for accessing all localized text, allowing for clean code without having to search for any constants or strings within the codebase.

#### **1.3.4.2 Rear interface**

A straightforward database-based interface class for the system, which outlines the available functions for the agent. Designating it as an interface provides versatility for the chatbot, as it can be adapted to work with a different type of backend by creating a new class that inherits from this interface.

#### **1.3.5 Executor of the action**

This component is in charge of executing instruction sequences. Works directly on the production of the Action Planner and sends messages and executes the planned instructions in the back.

## **2. Programming languages and libraries. Case Study: GAMMING1 chatbot**

An example of a chatbot in the context of customer service is GAMMING1. For the construction of GAMMING1 the Python programming language was chosen as the main language. The company that developed the chatbot primarily works with the .NET framework and writes a significant amount of code in C#. However, if the consideration is given to using Python, it can be noted that the language is relatively easy to learn and was deemed appropriate for this particular



scenario. There are also some libraries that can help on implementing a chatbot in practice. Keras bookstore is one of them. A recent survey showed that customers view chatbots positively. The survey was conducted by Drift in partnership with SurveyMonkey Audience, Salesforce, and myclever. Keras serves as the primary library for chatbots and offers a simple and user-friendly interface for various frameworks, including Tensorflow. In addition to Keras, chatbots also utilize the pandas library for efficient data storage and organization, especially when dealing with large amounts of data. Another significant library used in this context is scikit-learn, which is used to split data into testing and validation sets.

## **2.1 Data Extraction**

The first step in the process was to gather a collection of messages from the company's customer support system. The company has been using Zendesk since 2013, so there is a significant amount of data stored in their database. Unfortunately, Zendesk does not have a convenient way to export large amounts of ticket data, including the messages. To overcome this, a solution was devised to periodically extract new tickets on a weekly basis. To achieve this, a straightforward crawler API was developed. The software operates in a continuous loop and obtains ticket information in JSON format directly from the Zendesk API. This process retrieves a maximum of 100 tickets per request. It begins by selecting the earliest date, which serves as the starting point for retrieving tickets. The software then processes the tickets in order of their date and time. The software, following the processing of each group of 100 tickets, requests the next set of tickets to be processed. To ensure the security of the data, the software saves a backup of the tickets processed so far, after a predetermined number of tickets have been processed. This backup step is necessary in case of any system failures, as the full retrieval process of tickets is relatively quick. If a failure occurs, the software retrieves the last processed ticket from the backup file and resumes the process from that point. The software is designed to run on a periodic basis, such as weekly or monthly, to gather new ticket data and keep the template updated. Upon completion of retrieving all the tickets, they are categorized by language using the corresponding labels. The GAMING1 system can handle 9 different languages including French, Dutch, English, Portuguese, Spanish, Romanian, Serbian, German and Turkish. The distribution of tickets among these languages can be seen in Figure 21.

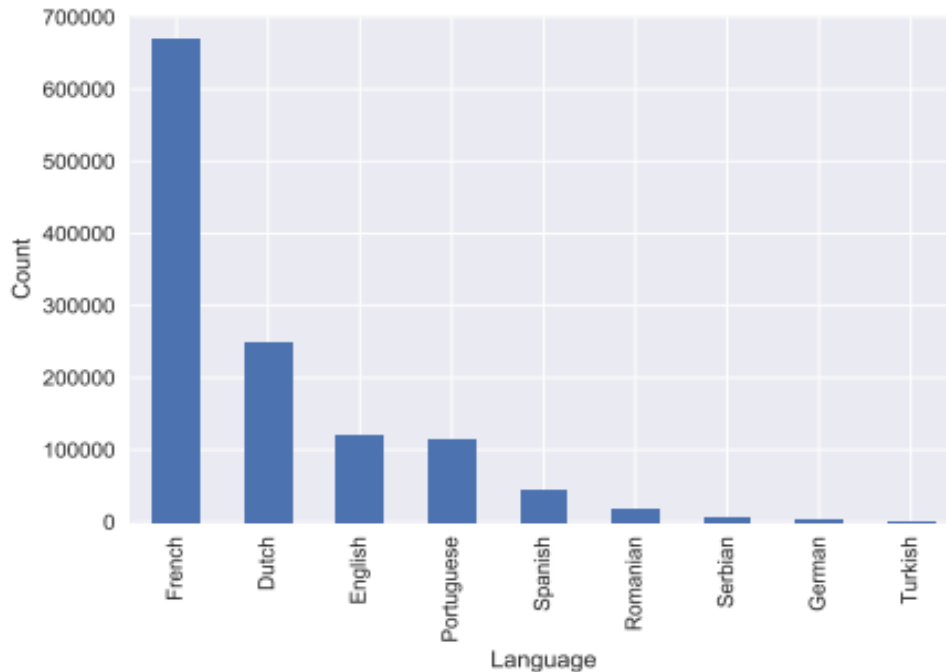

*Figure 21: Distribution by languages*

It is evident from the data that the distribution of tickets is heavily tilted towards the French language, accounting for nearly 48% of all tickets. The number of tickets for the remaining languages is relatively modest, except for Spanish, Romanian, Serbian, German, and Turkish, which have a low number of tickets. The minimum number of tickets for any language, in this case, is approximately 100,000 for Portuguese. The information obtained from the API encompasses a range of details, including the date the ticket was created, the time taken by customer service agents to resolve the ticket, the VIP status of the user, and the level of customer support provided for the ticket in question. While much of this information is not useful for the chatbot, it is intended for customer support managers to assess the performance of their workforce through monitoring statistical data. Therefore, only the initial message from the user and the "Tags" field will be utilized to train the chatbot. After the data sets for each language have been created, the crawler will be executed for each set, if there is a tab labeled with the corresponding ISO-639 language code in the ".csv" format. These files contain, in each row, the user's problem tag and a list of tags identifying the problem, which are often remnants of macro usage. The labels are specific to the language and therefore, a separate file should be created for each language. This will result in the creation of new data sets that will be used for target classification.

## 2.2 Generating responses

The component responsible for providing answers is known as the ActionPlanner. When the user's intent is correctly identified, it initiates the logic behind it. It may also communicate with the backend to verify details such as whether the user's account has been blacklisted or if a delay in the previous withdrawal was due to it being made from an international bank account. The responses are structured similarly to the responses that a customer support agent might give in a real-life scenario.

## 2.3 Database generation

The database cannot be fed information directly from the goal classifier due to the lack of proper labeling of the samples. However, since labels are attached to each macro, most user problems can be identified through the tags attached to the ticket. This is achieved by examining the list of labels attached to the ticket and determining if they correspond to specific types of labels that relate to a particular issue. Additionally, to facilitate fast experimentation and maximize efficiency, only the French ticket database will be utilized initially to test different network structures. This is because it is the largest data set, with roughly 600,000 tickets. It is believed that the distribution of classes in the French data set, as shown in Figure 22, accurately reflects the distribution of classes in other languages. However, it should be noted that the data set is highly imbalanced, with a significant concentration in one class.

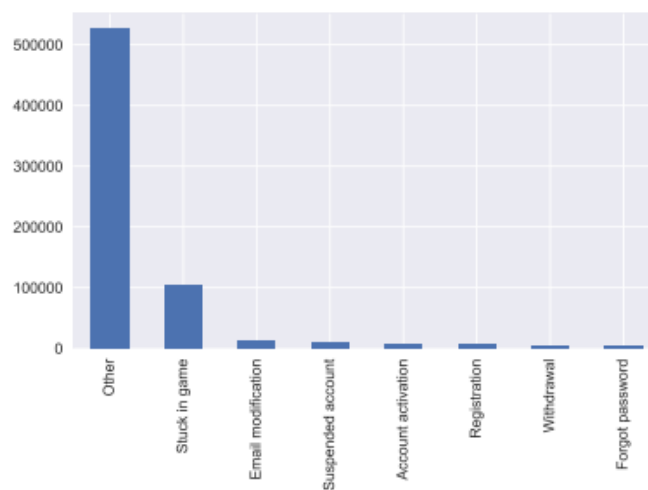
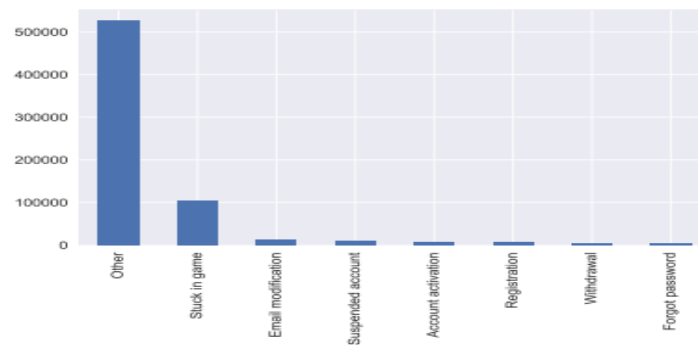

Figure 22: Distribution of the problem for France

In other words, the distribution of user issues in French and Dutch is similar, as shown in Figure 23. However, the proportion of the "Stuck in game" category is higher in French compared to Dutch. Despite this difference, it is still considered feasible to train the network using the French data set first, and then apply it to other languages. To evaluate the performance of the classification model, a simple training-validation-test approach is taken, with a split of 60/25/15 respectively. The label of each sample is also encoded into a binary vector, with 0s and 1s indicating the label of that sample.



*Figure 23: Distribution of the problem for France and the Netherlands*

## 2.4 Pre-processing

Because of their pattern, textual data cannot be entered straight into the neural network. A few extra small pre-processing steps will be required, before the actual training. They must be turned into sequences of integers of the same length. The pre-processing steps are listed below in the order in which they are performed:

- Return all lowercase characters.
- Filter trivial punctuation characters
- Token texts using words as signs. A word in this context is defined as a continuous sequence of characters surrounded by white space.
- Calculates the vocabulary of texts
- Replace each character in the sequences with their corresponding index in the dictionary.
- Set the sequences to a fixed length of 100 characters.

The final sequences obtained are suitable for neural networks training.

# **CHAPTER III**

## **CUSTOMER SERVICE SYSTEMS**

### **1. Introduction**

Live chat support has become a popular method of communicating with customers. It offers real-time customer service in e-commerce settings and enables customers to quickly get information or assistance with technical issues. This two-way communication has revolutionized customer service, making it more accessible and efficient, and has become the preferred method for customers seeking support over the past decade. As technology in Artificial Intelligence (AI) has advanced, there has been a trend towards using chat software agents such as chatbots to provide customer support instead of human chat services. These chatbots are designed to communicate with users in a similar way to human customer service representatives. Despite the early existence of rudimentary chat software agents (CAs) dating back to the 1960s, the recent advancements in Artificial Intelligence (AI) have reignited interest and investment in this technology. The "second wave of AI" has enabled the creation of more human-like chat systems. Nevertheless, customers still experience dissatisfaction with AI-powered CAs as they can provide inadequate answers to user inquiries, resulting in a mismatch between user expectations and the system's output. The rise of AI-powered chat software agents (CAs) as replacements for human customer support agents raises concerns about the continued effectiveness of live chat services. Skepticism and resistance towards technology may hinder task completion and lead to unsuccessful customer service experiences. Interactions with these systems can also result in undesired customer behaviors and a disconnect between service providers and users. However, if customers choose not to follow the guidance provided by CAs, the necessity of this self-service technology becomes questionable.

## **2. Automation in customer service**

Customer service plays a vital role for service-based companies. With the advancement of the internet, the way customer service is provided has shifted from being personal and conversation-based to being automated and self-service focused. However, this automation does not fully address the needs of customers for assistance and support, and the costs associated with manual customer service are still increasing. To meet customers' needs and channel them according to their preferences, service providers offer customer support through various online channels, including company websites, social media, email, and chat. As customers continue to prefer chat as their preferred method for receiving customer service, chatbots are becoming increasingly important in this field. Chat offers several advantages over other support channels such as email and phone, such as the ability for customer service representatives to handle multiple requests simultaneously and the provision of a written record of the conversation that can be referred to later. With these benefits, the use of chatbots to enhance customer service through chat is gaining prominence..

### **2.1 The concept of trust**

Trust is defined by Rousseau et al. as "a psychological state involving the intent to acknowledge vulnerability based on positive expectations of another's intentions or behavior." Trust plays a crucial role in situations that entail potential danger, as it enables the truster to rely on the trusted party. It encompasses both cognitive and emotional elements, as well as social components. Previous research on trust has examined its significance in interpersonal relationships, organizations, and society, and has highlighted its ability to promote a sense of unity and prevent disagreements and confrontations among individuals.

There is ongoing research on the topic of belief in technology, particularly in the case of robots. Hancock et al. have conducted a review on belief in robots and identified various factors that contribute to this belief, encompassing elements related to humans, robots, and the surroundings.

From the viewpoint of trust, the crucial elements that determine trust include dependability, ease of use, and potential for risk. Research has already established significant factors that can impact

users' trust in chatbots. However, given that chatbots have unique characteristics, it is crucial to specifically investigate trust in this technology to establish a more comprehensive understanding.

## **2.2 Benefits of chatbots for customer service**

According to studies conducted, the primary advantage of chatbots for customer service, is the ability for availability and information. Most study participants emphasized the fact that they received immediate responses and that they were not going to have to wait for a person to respond. Similarly, most competitors mentioned 24/7 access to customer service chatbots. According to them if they would talk to employees or managers, there is often waiting time. But chatbots have time endlessly. A considerable portion of the competitors also noticed as helpful that the chatbot works well for simple, general questions and provides answers that have gone through considerable quality control. Chatbot is in a credible method as well as does not just give a yes or no answer. Instead, you can see the way a chatbot analyses the question and will then answer it in the most accurate way possible. About half of the participants reported chatbots that carried other benefits as opposed to customer service with human staff. Foremost, some noticed that chatbots could reduce their threshold for asking questions. It was stated that when asking questions, a chatbot does not feel assessed - even when asking questions that one might believe that they are useless questions. When calling customer service, you are somehow careful not to ask too many simple or common questions. But against a chatbot you are somehow urged to ask common questions, in order to be a little more open. Additionally, some of the competitors noticed that since chatbots are not human they do not feel any time pressure. Therefore, they can take the time they feel is needed to formulate questions and return answers.

## **2.3 Challenges of chatbots for customer service**

The main concern raised by customers when it comes to chatbots providing customer service is the issue of miscommunication and misinterpretation. It states that the chatbot does not understand constantly what the client takes into consideration to ask. For instance, one study participant says: “The chatbot does not always comprehend what I am saying. When the chatbot does not understand the issue, I am stating, even though I can express it in different ways, this becomes annoying, and people would rather want to talk to a human in this case.

Additionally, some of the participants pointed out that chatbots often struggle with complex questions or questions pertaining to the specifics of their personal relationship with the service provider. This issue stems partially from the limitations in chatbots' ability to recognize users' intentions and from the fact that chatbots in customer service do not have access to the customer's personal information. This was reflected in the following statement made by participants in the study:

"My experience so far has been positive. But, of course, a chatbot is a chatbot, which means that it will be somewhat limited what you can take advantage of."

Additionally, the participants expressed worry over the security and privacy issues surrounding the use of chatbots in customer service. They were concerned about the need for service providers to guarantee the safety and privacy of their interactions with the chatbot, in the same way that they do with other online services. These concerns about security and privacy may also result in a perceived reduction in access to human customer service personnel. Participants raised concerns about the potential for decreased access to human customer service staff in the future, as chatbots become more prevalent. They emphasized the importance of maintaining the option for customers to seek help from human customer service representatives, even as chatbots become more efficient. The absence of this option could negatively impact the customer service experience.

## **2.4 Factors Affecting Trust in Chatbots for Customer Service**

A key concern among participants is the security aspect and factors that can affect their trust in chatbots for customer service. These factors can be divided into two categories: those that pertain to the chatbot itself and those that pertain to the context or environment in which the chatbot operates.

- Chat Factors related to chatbot. The repeatedly mentioned factors that affect trust in customer service chatbots had to do with the chatbot itself. Especially, the quality of chatbot interpretation as well as advice, also the human resemblance of the chatbot, self-presentation and level of professional appearance.
  - Interpretation and advice. Most participants believe that the accuracy in interpreting user inputs and the ability to provide helpful responses are critical in building trust in customer service chatbots. The chatbots' proficiency in efficiently resolving issues,



effectively matching questions with pertinent answers, and delivering high-quality answers were commonly discussed. This was the primary aspect mentioned by the participants.

- Similarity to humans. Most of the participants also linked the character of chatbots as a kind of unique to his communication style to potentially increase trust. Several participants argued that incorporating humor into chatbot communication, when appropriate, would boost trust. Others believed that a communication style that resembles human-to-human interaction would foster a sense of comfort. Some participants emphasized the importance of polite and humane communication in building trust in chatbots. The participants noted that the communication style of the chatbot played a significant role in creating a human-like experience. Additionally, the graphical design like for e.g., the name, the logo and the avatar of the chatbot would play a big role.
- Self-presentation and professional presentation. Many participants proposed that chatbots self-presentation would be significant for them to increase trust for the chatbot to clearly communicate what it is able to do better and how the chatbot can help the user. It was argued that this type of demonstration was particularly beneficial in showcasing conversation. Equally important, it was reported that it was important that the chatbot be open and honest about its limitations.

Several participants stated that their confidence in the chatbot would hinge on the level of thoughtful design it showcases. This encompasses both the appearance of the chatbot and the use of appropriate and accurate language.

- Factors related to the service context. Participants announced several factors that are seen as influential in the belief that they had nothing to do with chatbot as such, but with the overall context of the service. While factors related to the context of the service were reported less frequently than those related to the chatbot, they were still considered crucial by the users. These factors comprised of the chatbot's associated brand, perceived security and privacy, and perceived risk.
- Brand. Nearly half of the survey participants noted that the brand associated with the chatbot was a critical factor in building trust. The customer service chatbot is typically developed to support a specific brand, and users' perceptions of that brand were deemed

a crucial aspect in determining trust. The brand's impact on trust was perceived to stem not only from the chatbot's name, but also from its accessibility on the website.

- Security and privacy. A substantial portion of the respondents indicated that perceived security and privacy measures in the chatbot were crucial for building trust. Participants noted that users need to be confident that the chatbot's security is adequate, especially if it will handle transactions, not just provide answers to frequently asked questions. To facilitate transactions, it was also argued that the responsibility for any failure on the part of the chatbot should rest with the service provider, not the user.

The respondents also discussed the importance of understanding how their personal data is utilized and stored when interacting with the chatbot. They noted that the chatbot should clearly communicate what data is being stored, and, if feasible, minimize the storage of personal data.

The most important factor to consider when using chatbot in the future was the ability of chatbots to understand and provide sufficient help and information. This factor also affects their confidence levels. To be used regularly, and to be trusted, the chatbots need to interpret user questions properly, comprehend user needs, and deliver the help they need.

The participants emphasized the significance of an efficient interaction for their future use of customer service chatbots. Specifically, they discussed that the chatbot should be perceived as a more capable support channel than the alternatives available.

### **3. Implications for the future design of customer service chatbots**

The survey results had five major implications for the future design of customer service chatbots, which are crucial for the designers and developers of such chatbots.

1. Efficient service delivery is a priority. The primary factor that influences users' trust in customer service chatbots and their likelihood of becoming regular users is the efficient provision of the service.
2. Make the capabilities and limitations of chatbots transparent. Chatbots cannot address all customer's needs and wants, but they can still be a useful option for some. It is crucial for the chatbot to clearly communicate what it does best and how it can assist the user, so that

the user can make informed decisions about when the chatbot channel is the most appropriate choice.

- 3.** Improve user experience through human-like communication. A polite, personalized, and human-like demeanor can enhance the user experience and build trust in the chatbot. This human-like approach should not compromise efficiency and may add an additional layer of enjoyment, similar to that of a friendly and courteous customer service representative.
- 4.** Maximize the trust of users through the use of the brand. The brand behind the chatbot has a significant impact on users' trust in the chatbot. By leveraging the trust in the brand, designers and developers can boost confidence in the chatbot. On the other hand, a flawed design of the chatbot can have a negative impact on the reputation of the brand.
- 5.** Emphasize the importance of security and privacy in the design of the chatbot. It is essential to show users that their data and personal information will be protected when they use the chatbot. Clear communication about the measures taken to ensure security and privacy will build trust and confidence in the chatbot channel.

# CHAPTER IV

## CHATBOT SYSTEM

### Introduction

The built-in chatbot system is a simple system in which the user can perform a series of predefined queries and registered in the database. The "bot" database consists only of a "chatbot" table which stores the questions that the user can ask and the answers that the chatbot system can return. The database is built in MySql, the server used is Xampp.

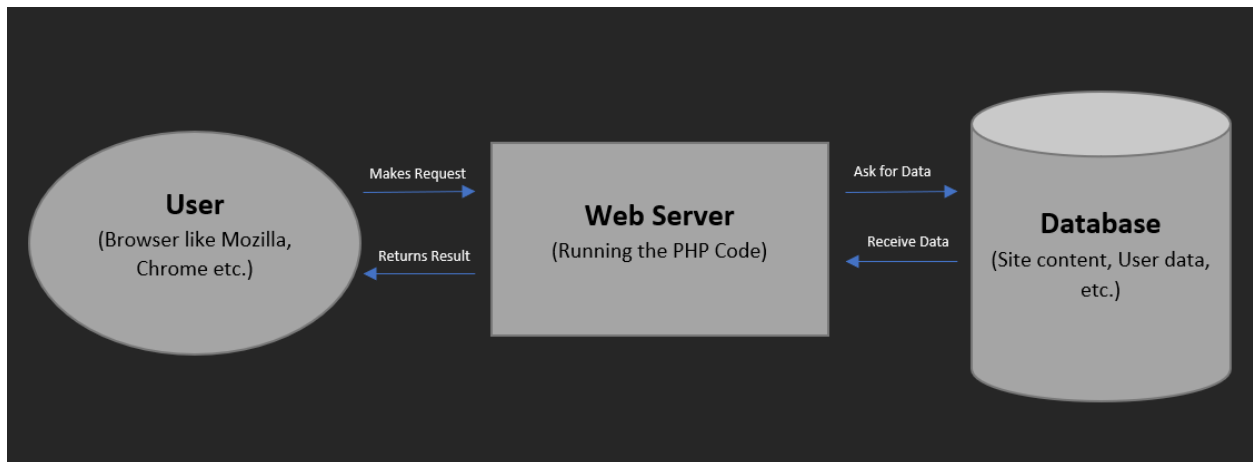

*Figure 24: Schema of the built-in chatbot system database*

The table stores the questions and answers as shown in the following figure:

The screenshot shows the phpMyAdmin interface for a database named 'bot' and a table named 'chatbot'. The table contains 13 rows of data. The selected row (id 7) is highlighted in green. The table structure is as follows:

id	queries	replies
1	Cfare je ti?	Une jam chatBot i ketij aplikacioni.
2	Cfare detyre ke?	Kam per detyre ti pergjigjem pyetjeve tuaja ? .
3	Si e ke emrin?	Une jam Alexa, chatBot i ketij aplikacioni.
4	Per cfare mund te te pyes?	Mund te me pyesesh ne lidheje me kete aplikacion ?
5	Cfare eshte php?	PHP (akronimi per PHP: Hypertext Preprocessor) es...
6	Cfare eshte nje chatbot?	Nje chatbot eshte nje aplikacion software qe perdo...
7	Hi	Hi :) si mund tju ndihmoj?
8	hello	Hi :)
14	po	Shume mire! Atehere nuk do me duhet tju shpjegoj s...
13	Nuk ndihem mire	Oh, me vjen keq! Ndoshta mund ta ndryshojme kete g...

Figure 25: Data in the chatbot table

To open the application in the browser, the file to be opened is bot.php which will return the following image:

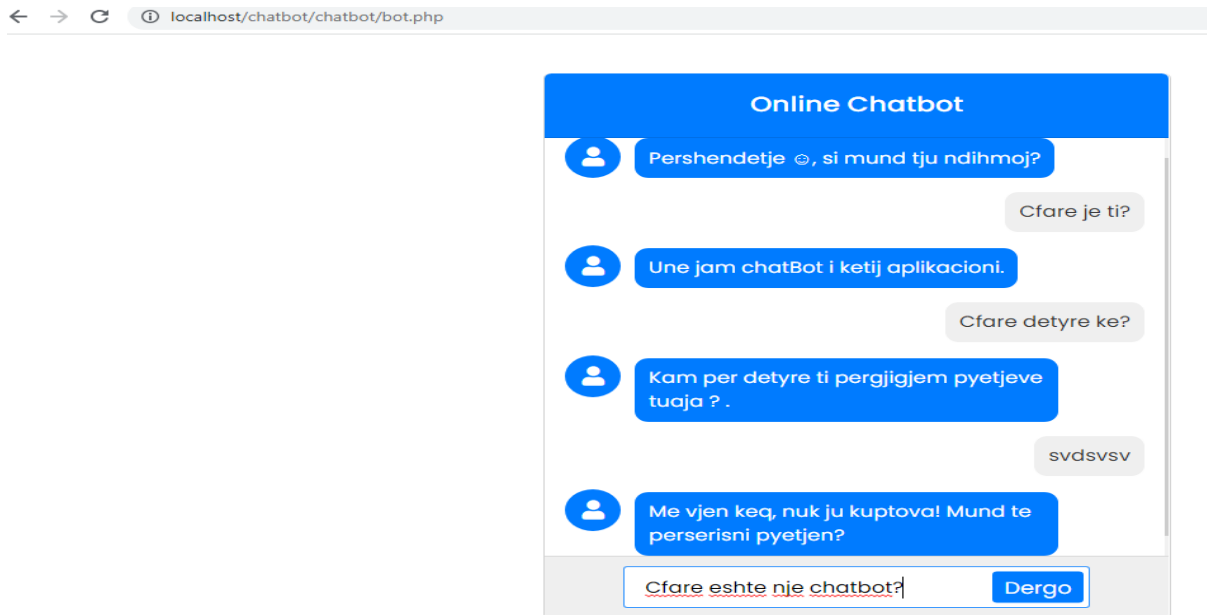

Figure 26: Chatbot system

The chatbot system code is written in PHP programming language and the HTML scripting language was used to build the graphical interface and the stylization was performed using CSS.

```

<div class="wrapper">
  <div class="title">Online Chatbot</div>
  <div class="form">
    <div class="bot-inbox inbox">
      <div class="icon">
        <i class="fas fa-user"></i>
      </div>
      <div class="msg-header">
        <p>Pershendetje 0, si mund tju ndihmoj?</p>
      </div>
    </div>
  </div>
</div>

```

The above code realizes the visual presentation of the chatbot. Awesome font icons were used in the design of the page elements. In the paragraph with the message: "Hello ☺, how can I help you?" the message that the chatbot displays when the page is loaded in the browser is defined. The box where the user writes the question, is realized through the part of the code as follows:

```

<div class="typing-field">
  <div class="input-data">
    <input id="data" type="text" placeholder="Shrkuaj pyetjen.." required>
    <button id="send-btn">Dergo</button>
  </div>
</div>

```

In the text field the user writes the query as instructed and by the placeholder set.

The information about which the chatbot can respond is stored in the database shown in Figure 25 above. To make the connection to the database, the `mysqli_connect` function is used, which takes as a parameter the name of the server, user and password of the database. of the database and the database to be operated on the server. The code is as follows:

```

$conn = mysqli_connect("localhost", "root", "", "bot") or die("Database Error");

```

The following function receives the query from the server via chatbot:

```

$getMesg = mysqli_real_escape_string($conn, $_POST['text']);

```

It is executed in the form of sql commands and then the following data retrieval is performed:

```

$check_data = "select replies FROM chatbot WHERE queries LIKE '%$getMesg%'";
$run_query = mysqli_query($conn, $check_data) or die("Error");

```

To display the data, the answer to the question asked for the chatbot, the received information is placed in vector format via the function `mysqli_fetch_assoc`, the answer field is accessed in the table and then it is displayed through the `echo` function.

```
$fetch_data = mysqli_fetch_assoc($run_query);  
  
$replay = $fetch_data['replies'];  
echo $replay;
```

## **Conclusions**

Artificial Intelligence-based chatbots have become increasingly popular in a variety of environments and possibly provide a range of time and cost savings options. Despite that, multiple users still experience inadequate experiences with chatbots, which can result in skepticism to technology, possibly preventing users from going along with the recommendations and requirements constructed by the chatbot. Additionally, the use of AI-powered chatbots can improve user engagement by tapping into the benefits of making the chatbot appear more human-like and the importance of consistency in digital customer service contexts. Customer service is a particularly well-suited area for the application of chatbots as it tends to involve structured interactions. The potential of Artificial Intelligence and Natural Language Processing in customer service is bright, as new and advanced techniques are continually emerging. It is possible that in the near future, chatbots will not only be able to communicate with humans effectively but also collaborate with other chatbots using human language, improving the quality of life. With time, the technology may even come close to replicating human behavior and capabilities.



## **Future Work**

In this thesis I have treated Chatbots and their impact on our everyday life. Imagine having fully trained and interactive Chatbots that can answer your Technology, Finance or Healthcare issues. This of course needs a huge amount of data.

What can be a future scope of Chatbots is that the conversational ability of chatbots should be upgraded. This would happen only if the NLP used on the Chatbot will be developed.

Another point to be discussed as a future scope is the Voice Interface. This method can be helpful for people with disabilities or those who are not in touch with technology. The latest will require another layer of NLP.

The points above mentioned will for sure improve the Customer Experience journey and this will also have an impact on the technology as well.

## References

1. Adam, M., Toutaoui, J., Pfeuffer, N., & Hinz, O. (2019). Investment decisions with robo-advisors: The role of anthropomorphism and personalized anchors in recommendations. In: Proceedings of the 27th European Conference on Information Systems (ECIS). Sweden: Stockholm & Uppsala.
2. Agarwal, R., & Prasad, J. (1998). A conceptual and operational definition of personal innovativeness in the domain of information technology. *Information Systems Research*, 9(2), 204–215.
3. Aggarwal, P., Vaidyanathan, R., & Rochford, L. (2007). The wretched refuse of a teeming shore? A critical examination of the quality of undergraduate marketing students. *Journal of Marketing Education*, 29(3), 223–233.
4. Araujo, T. (2018). Living up to the chatbot hype: The influence of anthropomorphic design cues and communicative agency framing on conversational agent and company perceptions. *Computers in Human Behavior*, 85, 183–189.
5. Artificial Intelligence, Intelligent Systems. Tutorialspoint.com
6. Bernd Carsten Stahl, Artificial Intelligence for a Better Future An Ecosystem Perspective on the Ethics of AI and Emerging Digital Technologies
7. Bem, D. J. (1972). Self-perception theory. *Advances in Experimental Social Psychology*, 6, 1–62.
8. Florian Peters, *Desing and implementation of a chatbot in the context of customer support. 2018*
9. Benlian, A., Klumpe, J., & Hinz, O. (2019). Mitigating the intrusive effects of smart home assistants by using anthropomorphic design features: A multimethod investigation. *Information Systems Journal*.
10. Bertacchini, F., Bilotta, E., & Pantano, P. (2017). Shopping with a robotic companion. *Computers in Human Behavior*, 77, 382–395.
11. Bickmore, T. W., & Picard, R. W. (2005). Establishing and maintaining long-term human-computer relationships. *ACM Transactions on Computer-Human Interaction (TOCHI)*, 12(2), 293–327.
12. Bowman, D., Heilman, C. M., & Seetharaman, P. (2004). Determinants of product-use compliance behavior. *Journal of Marketing Research*, 41(3), 324–338.

- 13.** Burger, J. M. (1986). Increasing compliance by improving the deal: The that's-not-all technique. *Journal of Personality and Social Psychology*, 51(2), 277.
- 14.** Burger, J. M. (1999). The foot-in-the-door compliance procedure: A multiple-process analysis and review. *Personality and Social Psychology Review*, 3(4), 303–325.