

# **Measurement and Simulation of the Sound Insulation of Double Leaf Facades with Openings for Natural Ventilation**

**Egzon Bajraktari, Josef Lechleitner, Ardeshir Mahdavi**  
Department of Building Physics and Building Ecology  
Vienna University of Technology  
Karlsplatz 13, Vienna, Austria  
bpi@tuwien.ac.at

## **ABSTRACT**

This paper deals with the acoustical properties of a double leaf facade with openings for natural ventilation. Specifically, we explore the potential for the prediction of the sound reduction index of such double leaf facades via acoustical simulation. The subject of the exploration is an experimental modular double-leaf system with multiple opening possibilities. Different elements can be opened in both layers, such that multiple opening configurations can be studied both empirically and computationally. The actual performance of the wall was captured via parametric laboratory measurements. The respective configurations were then modelled using a state-of-the-art room acoustics simulation program. Computer simulation and laboratory measurement results were compared. The results suggest that currently the acoustical performance of the double-leaf wall system cannot be accurately predicted using simulation. Likely reasons for this circumstance as well as potential improvements are discussed.

**KEYWORDS:** building envelope, noise control, natural ventilation, acoustics, simulation

## **1 INTRODUCTION**

Computer simulation techniques have greatly increased the potential for the acoustical evaluation of structures and spaces (Svensson 2008). Following principles of classical geometric acoustics, computer simulations in room acoustics have been widely studied in the last 50 years (Vorländer 2013). A number of commercial acoustic simulation tools have been developed and are already in use. Their reliability and usability is tested and discussed (Vorländer 1995, Bork 2000, 2005, Mahdavi 2011). Advanced acoustical simulation software include algorithms for calculating sound transmission through partition elements from a source room to a receiving room (Rindel and Christensen 2008).

This contribution explores the possibility of using computer simulation for predicting the sound insulation of double leaf facades (DLF) with openings for natural ventilation.

## **2 APPROACH**

Our Department of Building Physics and Building Ecology at the Vienna University of Technology has conducted studies regarding a novel double leaf façade (Mahdavi et al. 2012, 2013) that allows natural ventilation while providing sufficient sound insulation. Thus, a modular flexible instance of a double leaf facade is installed in our laboratory (Fig. 1 and 2) placed in the opening between two adjacent

reverberant chambers. The source room and receiving room of the laboratory have a floor surface of 30.4 m<sup>2</sup> and 30.6 m<sup>2</sup> respectively and a height of 6.8 m. The experimental DLF (dimensions 3.1 x 3.1 m) consists of two layers (0.43 m apart from each other) of chip-board panels (acoustically highly reflective) tightly mounted on aluminium bars. In a grid structure of 5 x 5, each layer has 25 dismountable chip-board square panels (dimension 0.50 x 0.50 m).



Figure 1: View of the experimental double-wall with the frame structure for the installation of flexible (individually removable) modular components

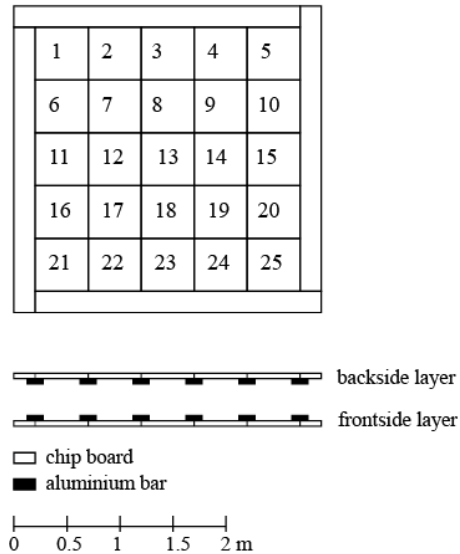

Figure 2: Schematic illustration of the double-layered modular experimental wall

This flexible construction allows us to parametrically modify a number of relevant variables that affect the sound insulation of double leaf facades. Namely, opening area (we can open and close one or more panels on each layer), distance between openings (openings on both layers can be arranged so as to face each other, or to be shifted – see Figure 3), and cavity sound absorption (we can add absorption panels in the cavity space between two layers). Sound insulation properties of a comprehensive sequence of configurations were captured via systematic laboratory measurements (Mahdavi et al. 2012, 2013). These configurations are summarized in Table 1.

For simulation, the modelling of the geometry of both source and receiving rooms of the acoustic laboratory and the experimental DLF has been done via SketchUp 8.0 (TNL 2012) and then simulated in Odeon 12.0 Combined (Odeon 2013). Odeon uses a hybrid method combining image source method and ray-tracing for calculating room acoustic parameters (Christensen and Koutsouris 2013).

The geometry of the test configuration was modelled in a relatively simple fashion (see Figure 4), as adding further details to geometry did not have a noteworthy impact on the simulation results (Bork 2005, Siltanen et al. 2008). Materials and their absorption coefficients were chosen from the existing library, related literature sources, and when available, from producer specifications. The model was calibrated through an iterative process. Thereby, certain simulation input variables (absorption coefficients of surface materials) were adjusted to achieve a better match between simulation results and corresponding measurements (specifically, reverberation times in both source and receiving rooms of the laboratory) (Tugrul et al. 2012).

Since there is little known about scattering properties of materials, default input from the simulating software was used. As to the simulation settings, “Precision” setting was used, as well as transition order 2, number of late rays 32000, impulse response length 5000 ms. Calculation of sound

transmission from one space in another in Odeon is handled so that a certain fraction of sound “particles” are let through the transmitting “wall” and the rest are reflected back, whereas energy is adjusted by multiplying in both cases with respective factors (Rindel and Christensen 2008). Sound reduction index in third-octave bands for the transmitting “wall” must be given, and in this case it is taken from the laboratory measurements results.

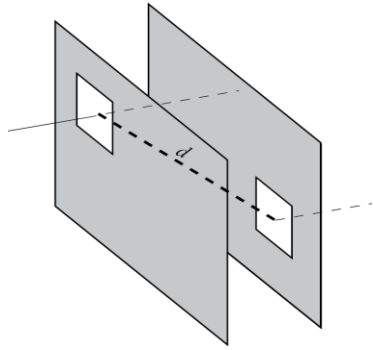

Figure 3: Illustration of distance between open elements (d).

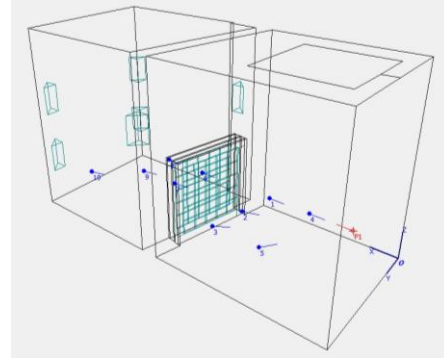

Figure 4: Screenshot of the simulation model

Table 1 Measured and simulated configurations of DLF (see Figure 2 for the numeric code of the elements). Note that the elements' distance (d) denotes the spatial distance between the centre points of the open elements (Fig. 3)

Config.	Code of the open elements in the front leaf	Front leaf elements with added absorption	Code of the open elements in the back leaf	Back leaf elements with added absorption	Distance d (m)
1	none	none	none	none	
2	none	none	all	none	
3	7	none	all	none	
4	1	none	1	none	0.43
5	1	none	7	none	0.83
6	1	none	13	none	1.48
7	1	none	19	none	2.16
8	1	none	25	none	2.86
9	6, 16	none	6, 16	none	0.43
10	6, 16	none	7, 17	none	0.66
11	6, 16	none	8, 18	none	1.09
12	6, 16	none	9, 19	none	1.56
13	6, 16	none	10, 20	none	2.05
14	1, 6, 11, 16, 21	none	1, 6, 11, 16, 21	none	0.43
15	1, 6, 11, 16, 21	none	3, 8, 14, 18, 23	none	1.09
16	1, 6, 11, 16, 21	none	5, 10, 15, 20, 25	none	2.05
17	6, 16	2, 7, 12, 17, 22, 4, 9, 14, 19, 24	6, 16	none	0.43
18	6, 16	2, 7, 12, 17, 22, 4, 9, 14, 19, 24	8, 18	none	1.09
19	6, 16	2, 7, 12, 17, 22, 4, 9, 14, 19, 24	10, 20	none	2.05
20	1, 6, 11, 16, 21	2, 7, 12, 17, 22, 4, 9, 14, 19, 24	1, 6, 11, 16, 21	none	0.43
21	1, 6, 11, 16, 21	2, 7, 12, 17, 22, 4, 9, 14, 19, 24	3, 8, 14, 18, 23	none	1.09
22	1, 6, 11, 16, 21	2, 7, 12, 17, 22, 4, 9, 14, 19, 24	5, 10, 15, 20, 25	none	2.05
23	6, 16	2, 7, 12, 17, 22, 4, 9, 14, 19, 24	6, 16	2, 7, 12, 17, 22, 4, 9, 14, 19, 24	0.43
24	6, 16	2, 7, 12, 17, 22, 4, 9, 14, 19, 24	8, 18	2, 7, 12, 17, 22, 4, 9, 14, 19, 24	1.09
25	6, 16	2, 7, 12, 17, 22, 4, 9, 14, 19, 24	10, 20	2, 7, 12, 17, 22, 4, 9, 14, 19, 24	2.05
26	1, 6, 11, 16, 21	2, 7, 12, 17, 22, 4, 9, 14, 19, 24	1, 6, 11, 16, 21	2, 7, 12, 17, 22, 4, 9, 14, 19, 24	0.43
27	1, 6, 11, 16, 21	2, 7, 12, 17, 22, 4, 9, 14, 19, 24	3, 8, 14, 18, 23	2, 7, 12, 17, 22, 4, 9, 14, 19, 24	1.09
28	1, 6, 11, 16, 21	2, 7, 12, 17, 22, 4, 9, 14, 19, 24	5, 10, 15, 20, 25	2, 7, 12, 17, 22, 4, 9, 14, 19, 24	2.05

The aforementioned configurations (Table 1) were computed using the calibrated simulation model. Subsequently, the simulation results were compared with measurement results. Thereby, measured and simulated reverberation times as well as frequency-dependent and weight sound reduction indices were compared.

### 3 RESULTS

#### 3.1 Reverberation time (T)

Figure 5 illustrates the generally good agreement between simulated and measured reverberation time values for a sample of configurations. The errors (particularly in the low-frequency range) may be due, in part, to the following circumstance. Reverberation time simulation only takes the room surface absorption coefficients into account. Specifically, the complex vibrational behaviour of the DLF is not explicitly modelled. Hence, simulation delivers the same values for configurations 1 and 2 (see Figure 6), whereas measurements reflect the behaviour of the entire complex structure.

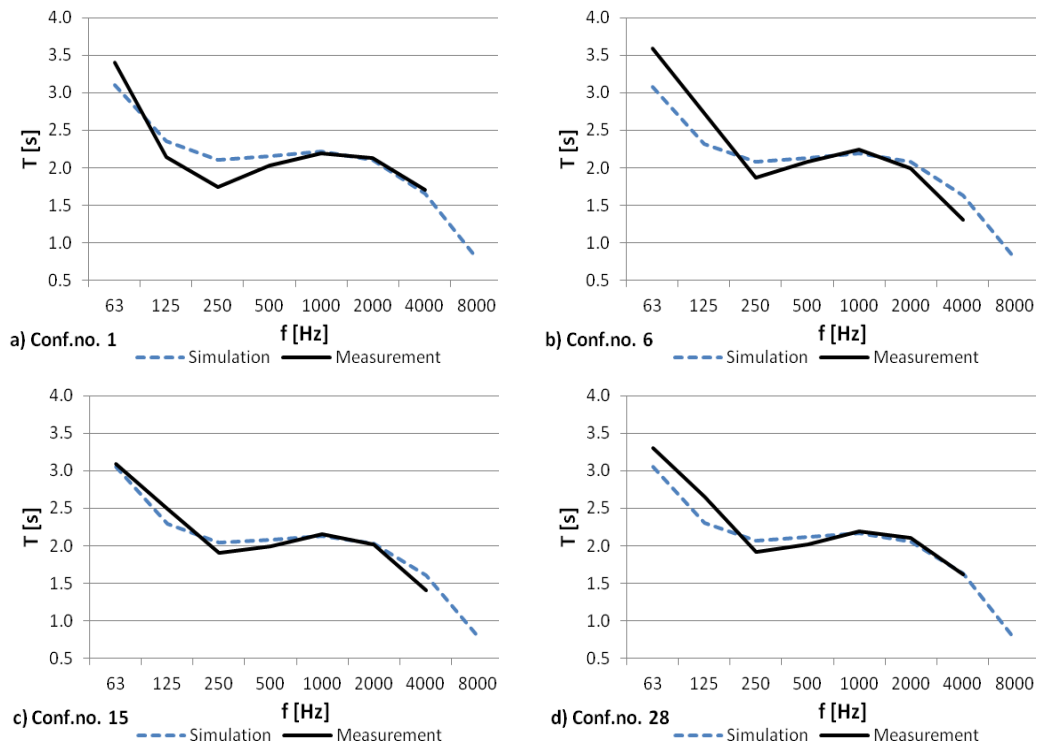

Figure 5: Comparison of simulated vs. measured reverberation time (T) in configurations no. (a) 1, (b) 6, (c) 15, (d) 28 (See Table 1 for the configuration properties)

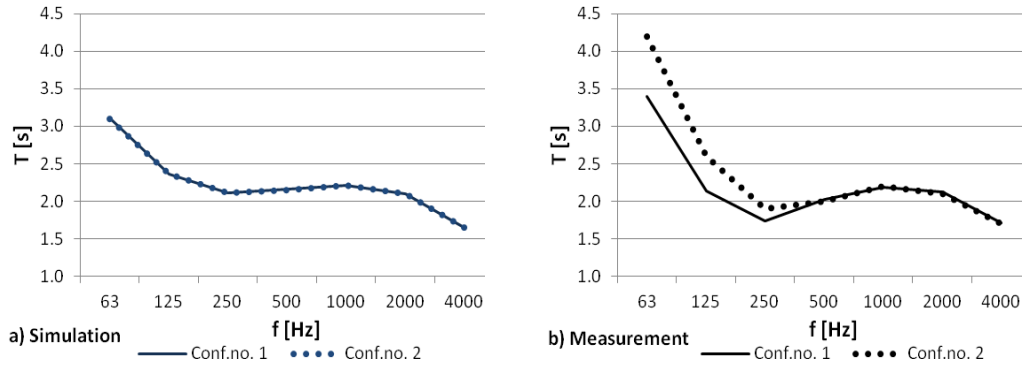

Figure 6: Comparison of simulated (a) vs. measured (b) reverberation time results of configurations no. 1 (both layers closed – double leaf facade) and 2 (one layer closed – single leaf facade) (See Table 1 for the configuration properties)

### 3.2 Sound reduction index (R)

Figure 7 includes both measured and simulated sound reduction indices. Figure 8 shows the overall relationship between measured and simulated frequency-dependent sound reduction indices. Simulation results show large errors especially in low frequencies (125, 250 Hz). This holds true no matter the amount of sound absorption in the cavity of DLF. When openings are shifted (displaced in relation to each other) the errors tend to become smaller, especially for the middle frequencies (500, 1000 Hz). The best fit is obtained when one side of the cavity (one layer of DLF) is furnished with sound absorption panels and the openings are maximally displaced.

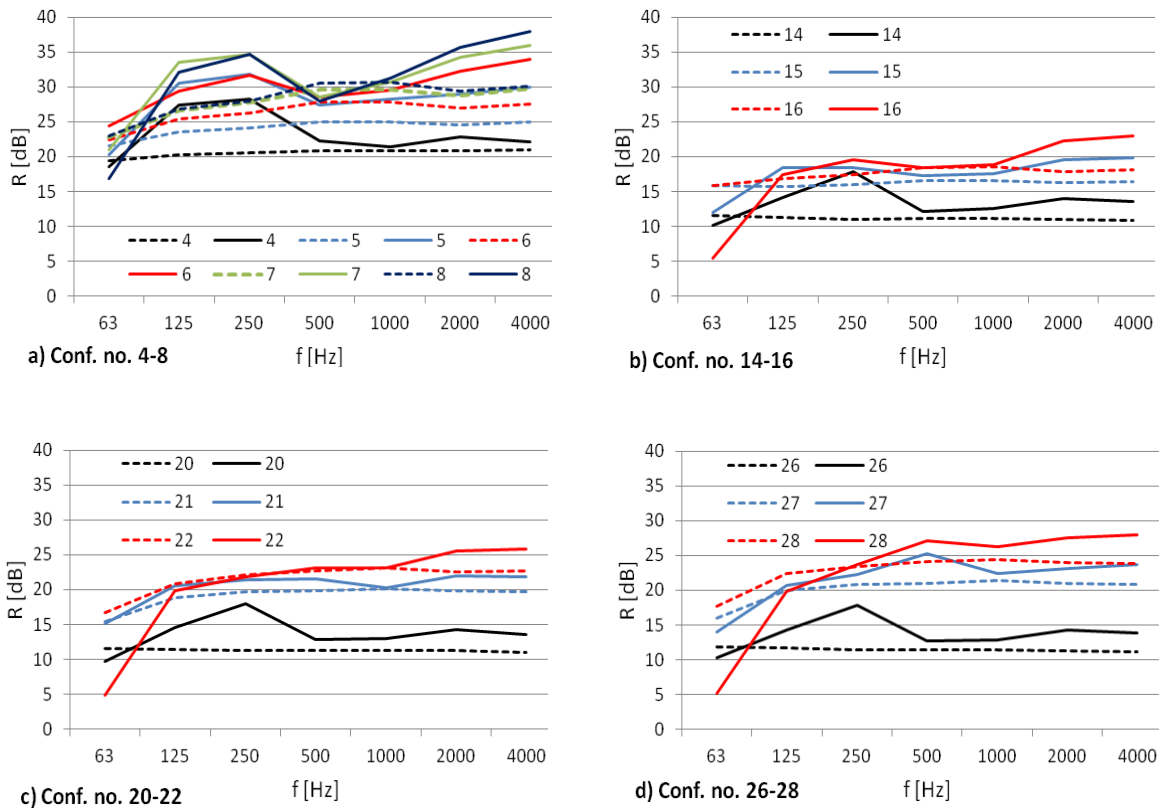

Figure 7: Comparison of simulated (dotted lines) vs. measured (continuous lines) sound reduction index ( $R$ ) for four groups of configurations: a) configurations 4-8; b) configurations 14-16; c) configurations 20-22; d) configurations 26-28 (see Table 1 for configuration specifications)

### 3.3 Weighted sound reduction index ( $R_w$ )

Using simulation results and following the standard procedure (ISO 2013), weighted sound reduction index ( $R_w$ ) was calculated for each of the 28 simulated DLF configurations (see Figure 9). A comparison of these simulation-based weight sound reduction index values ( $R_{w, \text{sim}}$ ) to the measured  $R_w$  results shows that 36% of simulated  $R_{w, \text{sim}}$  values lie within an error margin of  $\Delta R_w = 1$  dB, whereas 86% fall within an error margin of  $\Delta R_w = 2$  dB. Mean error was found to be  $\Delta R_w = 1.4$  dB.

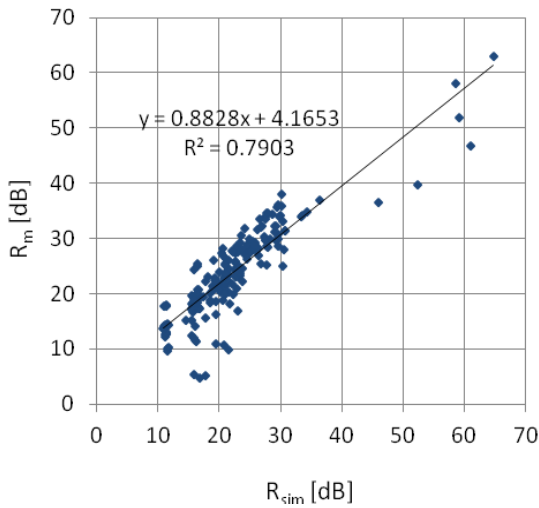

Figure 8: Simulated ( $R_{\text{sim}}$ ) vs. measured ( $R_m$ ) sound reduction index

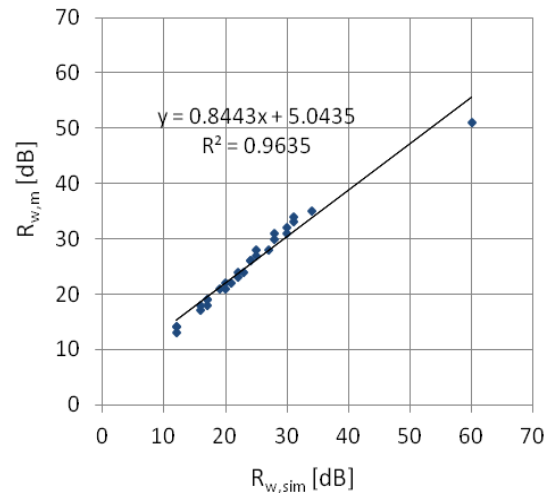

Figure 9: Simulated ( $R_{w, \text{sim}}$ ) vs. measured ( $R_{w, m}$ ) weighted sound reduction index

## 4 DISCUSSION

From the comparison results, we can conclude that the simulation results do not reproduce the frequency-dependency visible in the measurement results. A potential explanation for this circumstance pertains to the fact that the deployed simulation tool currently does not model the complex wave phenomena inside the DLF cavity (Bork 2005, Vorländer 2013). This conjecture is corroborated by the observation that better simulation results are achieved in case of configurations with displaced openings, which also have somewhat higher cavity absorption (Figure 9).

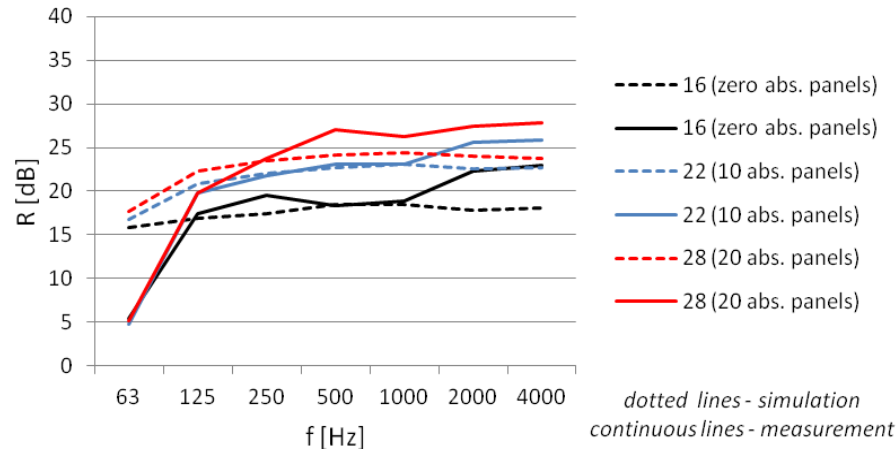

Figure 10: Comparison of simulated (dotted lines) vs. measured (continuous lines) sound reduction index of DLF configurations with openings of same size (1.25 m<sup>2</sup>) shifted against each other 2.05 m, with three cavity absorption options: no absorption panels (conf. 16), 10 absorption panels (conf. 22), and 20 absorption panels (conf. 28) (see Table 1 for the configuration properties)

## 5 CONCLUSION

We compared the measured and simulated results (reverberation times, frequency-dependent and weighted sound reduction index values) of the acoustical analysis of a double leaf facade (DLF) with openings for natural ventilation. The results suggest that currently the acoustical performance of the double leaf facade cannot be accurately predicted using simulation, even though the simulation model was calibrated using measured values of reverberation times. Specifically, the frequency dependency of the measured values of the sound insulation of the DLF could not be accurately reproduced via simulation. A contributing factor to this circumstance may lie in the simulation algorithm's disregard of complex wave phenomena in the cavity space between the two layers of the DLF. A better predictive performance could be achieved while computing the weighted sound reduction index values. The difference between the measured and simulation-based values was in this case for a large majority of the cases less than 2 dB. It is expected that ongoing efforts in advanced room acoustics simulation including wave phenomena (Savioja 2010, Kowalczyk and van Walstijn 2011, Borrel-Jensen 2012) could improve the overall performance of simulation tools, leading also to better future results concerning DLF analysis.

## REFERENCES

- Bork I. 2000. A comparison of room simulation software – The 2nd round robin on room acoustical computer simulation. *Acustica united with acta acustica* 86 (2000) 943–956.
- Bork I. 2005. Report on the 3rd Round Robin on Room Acoustical Computer Simulation – Part II: Calculations. *Acta Acustica united with Acustica*, Vol. 91, 753-763
- Borrel-Jensen N. 2012. Real-time auralisation of the lower frequency sound field using numerical methods on the GPU. Master thesis, RWTH Aachen University, and University of Copenhagen.
- Christensen C L, Koutsouris G. 2013. ODEON Room Acoustics Software, Version 12 – User Manual. 2nd Edition. Odeon A/S, 2013, Lyngby, Denmark.

- ISO. 2013. ISO 717-1, Acoustics – Rating of sound insulation in buildings and of building elements. Part 1: Airborne sound insulation
- Kowalczyk K, van Walstijn M. 2011. Room acoustics simulation using 3D compact explicit FDTD schemes. *IEEE Trans. Audio, Speech, Lang. Process.* 19(3), 34 (2011).
- Mahdavi A. 2011. “Room acoustics performance prediction” in: "Building Performance Simulation for Design and Operation", J. Hensen, R. Lamberts (Ed.); Taylor & Francis, New York, 2011, ISBN: 9780415474146, S. 218 - 234.
- Mahdavi A, Çakir O, Pröglhöf C, Lechleitner J. 2012. Sound insulation of a double-leaf wall system with openings for natural ventilation. *Proceedings of the 5th International Building Physics Conference (IBPC)*, Kyoto, Japan. pp: 1115-1118.
- Mahdavi A, Bajraktari E, Hintermayer M, Lechleitner J. 2013. Sound Insulation of Double Facades with Operable Windows: an Empirical Inquiry. “CLIMA 2013 - 11th REHVA World Congress and the 8th International Conference on Indoor Air Quality, Ventilation and Energy Conservation in Buildings”, K. Kabele, M. Urban, K. Suchý, M. Lain (Ed.); Society of Environmental Engineering (STP), 1/1/1 (2013), Paper-Nr. 275, 8 S.
- Odeon. 2013. Odeon 12.0 Combined. Odeon A/S, Denmark. ([www.odeon.dk](http://www.odeon.dk), accessed 12.02.2014)
- Rindel J. H., Christensen C. L. 2008. Modelling airborne sound transmission between coupled rooms. *Joint Baltic-Nordic Acoustics Meeting 2008*
- Savioja L. 2010. Real-time 3D finite-difference time-domain simulation of mid-frequency room acoustics. In *Proceedings of the 13th International Conference on Digital Audio Effects, DAFX Graz, Austria (2010)*, p. 43.
- Siltanen S, Lokki T, Savioja L, Christensen C L. 2008. Geometry Reduction in Room Acoustics Modeling. *Acta Acustica united with Acustica*, Vol. 94 (2008)
- Svensson P. 2008. The Early History of Ray Tracing in Room Acoustics. Reprint from “Reflections on sound In honour of Professor Emeritus Asbjørn Krokstad”, Edited by Peter Svensson, Trondheim, June 2008. ISBN 978-82-995422-3-4
- TNL. 2012. SketchUp Version 8.0. Trimble Navigation Ltd. ([www.sketchup.com](http://www.sketchup.com), accessed 03.12.2013)
- Tugrul A, Lechleitner J, Schuß M, Mahdavi A. 2012. Exploring the role of simulation in room acoustical retrofit of office spaces: a case study. *Fourth German-Austrian IBPSA Conference BauSIM 2012*
- Vorländer M. 1995. International round robin on room acoustical computer simulations. *15th International Congress on Acoustics*, Trondheim, Norway 26-30 June 1995.
- Vorländer M. 2013. Computer simulations in room acoustics: Concepts and uncertainties. *J. Acoust. Soc. Am.*, Vol. 133, No. 3, March 2013